Installation manual

Terra AC

Copyright

All rights to copyrights, registered trademarks, and trademarks reside with their respective owners.

Copyright © ABB EV Infrastructure. All rights reserved.

Contents

1	About this document.....	7
1.1	Function of this document.....	7
1.2	Target group.....	7
1.3	Revision history.....	7
1.4	Language.....	7
1.5	Illustrations.....	7
1.6	Units of measurement.....	7
1.7	Typographical conventions.....	7
1.8	How to use this document.....	7
1.9	General symbols and signal words.....	8
1.10	Special symbols for warnings and dangers.....	9
1.11	Related documents.....	9
1.12	Manufacturer and contact data.....	10
1.13	Abbreviations.....	10
1.14	Terminology.....	10
1.15	Orientation agreements.....	11
2	Description.....	12
2.1	Short description.....	12
2.2	Intended use.....	12
2.3	Product label (IEC portfolio).....	12
2.4	Product label (UL portfolio).....	13
2.5	Working principle.....	14
2.6	Overview.....	15
2.6.1	Overview of the system.....	15
2.6.2	Overview of the EVSE, outside.....	15
2.6.3	Overview of the EVSE, inside (CE model).....	17
2.6.4	Overview of the EVSE, inside (MID model).....	18
2.6.5	Overview of the EVSE, inside (UL model).....	19
2.6.6	Overview of the EVSE, inside (UL model with display).....	20
2.7	Options.....	21
2.7.1	Display.....	21
2.7.2	EV charge cable, Type 2.....	21
2.7.3	Socket, Type 2.....	21
2.7.4	EV charge cable, Type 1 (UL portfolio).....	22
2.7.5	4G Communication.....	22
2.7.6	Load management	22
2.8	Control elements.....	23
2.8.1	LED indicators.....	23
2.9	TerraConfig app to do the commissioning	24

2.10	Description of the display screens (option).....	24
2.10.1	Boot screen.....	24
2.10.2	Standby/Idle screen.....	25
2.10.3	Authorization screen.....	25
2.10.4	Preparing to charge screen.....	26
2.10.5	Charging screen.....	26
2.10.6	Charging completed screen.....	27
2.10.7	Fault detected display messages.....	27
3	Safety.....	29
3.1	Liability.....	29
3.2	Required qualifications for the installation engineer.....	29
3.3	Personal protective equipment.....	29
3.4	FCC compliance statement.....	30
3.5	Industry Canada compliance statement.....	30
3.6	General safety instructions.....	31
3.7	Signs on the EVSE.....	31
3.8	Discard the EVSE or parts of the EVSE.....	32
3.9	Safety instructions for earthing.....	32
3.10	Special safety instructions (IEC portfolio).....	32
3.10.1	Safety instructions during installation.....	32
3.11	Special safety instructions (UL portfolio).....	33
3.11.1	Additional important safety instructions.....	33
4	Installation.....	34
4.1	General installation procedure.....	34
4.2	Unpack the EVSE.....	34
5	Site preparation.....	35
5.1	Select the site	35
5.2	Prepare the site (IEC portfolio).....	35
5.3	Prepare the site (UL portfolio).....	35
6	Mechanical installation.....	37
6.1	General mechanical installation procedure.....	37
6.2	Prepare the holes for the mounting screws.....	37
6.3	Install the upper mounting screws.....	38
6.4	Install the EVSE on the wall.....	38
7	Electrical installation.....	39
7.1	General electrical installation procedure.....	39
7.2	Insert the AC input cable.....	39

7.3	Connect the AC input cable.....	40
7.3.1	Connect the AC input cable, 1 phase (IEC portfolio).....	40
7.3.2	Connect the AC input cable, 3 phase (IEC portfolio).....	40
7.3.3	Connect the AC input cable (UL portfolio).....	41
7.3.4	Secure the cables.....	41
7.4	Communication connections.....	42
7.4.1	Insert the Ethernet cable.....	42
7.4.2	Connect the Ethernet cable.....	42
7.4.3	Insert the wires for the smart meter communication.....	43
7.4.4	Connect the wires for the smart meter communication.....	43
7.4.5	Insert the Nano-M2M SIM card.....	44
7.5	Replace the EV charge cable.....	44
7.5.1	Replace the EV charge cable, 1 phase (IEC portfolio).....	44
7.5.2	Replace the EV charge cable, 3 phase (IEC portfolio).....	45
7.5.3	Replace the EV charge cable (UL portfolio).....	46
8	Commissioning.....	48
8.1	General commissioning procedure.....	48
8.2	Energize the EVSE.....	48
8.3	Set up the EVSE.....	48
9	Access to parts.....	50
9.1	Remove the cabinet cover.....	50
9.2	Install the cabinet cover.....	50
9.3	Remove the maintenance cover.....	51
9.3.1	Remove the maintenance cover (EVSE without display).....	51
9.3.2	Remove the maintenance cover (EVSE with display).....	51
9.4	Install the maintenance cover.....	52
9.4.1	Install the maintenance cover (EVSE without display).....	52
9.4.2	Install the maintenance cover (EVSE with display).....	52
9.5	Remove the inner cover.....	53
9.5.1	Remove the inner cover (EVSE without display).....	53
9.5.2	Remove the inner cover (EVSE with display).....	53
9.6	Install the inner cover.....	54
9.6.1	Install the inner cover (EVSE without display).....	54
9.6.2	Install the inner cover (EVSE with display).....	54
10	Troubleshooting.....	55
10.1	Troubleshooting procedure.....	55
10.2	Troubleshooting table (IEC portfolio).....	55
10.3	Troubleshooting table (UL portfolio).....	58
10.4	De-energize the EVSE.....	61

11	Technical data.....	62
11.1	EVSE Type.....	62
11.2	General specifications.....	63
11.3	Ambient conditions.....	64
11.4	Mass	64
11.5	Protective device compliance.....	65
	11.5.1 Protective device compliance (IEC portfolio).....	65
	11.5.2 Protective device compliance (UL portfolio).....	65
	11.5.3 Protective device compliance (Singapore).....	66
11.6	Parts included in the delivery.....	66
11.7	Required tools for installation.....	66
11.8	Requirements for the wall.....	67
11.9	Noise level.....	67
11.10	Dimensions.....	67
	11.10.1 AC input with socket, cable Type 2.....	67
	11.10.2 AC input with EV charge cable.....	68
	11.10.3 Space requirements for installation.....	69
11.11	AC input specifications.....	69
	11.11.1 General specifications.....	69
	11.11.2 400 VAC 3-phase with neutral (TT, TN) (IEC portfolio).....	70
	11.11.3 230 VAC 1-phase (IEC portfolio).....	70
	11.11.4 240 VAC (UL portfolio).....	70
	11.11.5 AC input specifications (IEC portfolio).....	70
	11.11.6 AC input specifications (UL portfolio).....	71
11.12	General logic interface specifications.....	71
11.13	Cable specifications.....	71
	11.13.1 AC input cable (IEC portfolio).....	71
	11.13.2 AC input cable (UL portfolio).....	72
	11.13.3 Ethernet cable specifications.....	72
	11.13.4 RS485 cable specifications.....	72
	11.13.5 Dry contacts input.....	73
	11.13.6 Dry contacts output.....	73
	11.13.7 EV charge cable specifications (IEC portfolio).....	74
	11.13.8 EV charge cable specifications (UL portfolio).....	74
11.14	AC output specifications.....	74
	11.14.1 AC output specifications (IEC portfolio).....	74
	11.14.2 AC output specifications (UL portfolio).....	74
11.15	Torque specifications.....	75

1 About this document

1.1 Function of this document

The document is only applicable for this EVSE (Terra AC), including the variants and options listed in section 11.1. The EVSE from here on in the document is referred to as the EVSE.

The document gives the information that is necessary to do these tasks:

- Installation
- Commissioning

1.2 Target group

The document is intended for qualified installation engineers.

For a description of the required qualifications, refer to section 3.2.

1.3 Revision history

Version	Date	Description
001	March 2020	Initial version
002	April 2021	Complete document overhaul

1.4 Language

The original instructions of this document are in English (EN-US). All other language versions are translations of the original instructions.

1.5 Illustrations

It is not always possible to show the configuration of your EVSE. The illustrations in this document show a typical setup. They are for instruction and description only.

1.6 Units of measurement

SI units of measurement (metric system) are used. If necessary, the document shows other units between parentheses () or in separate columns in tables.

1.7 Typographical conventions









The lists and steps in procedures have numbers (123) or letters (abc) if the sequence is important.



1.8 How to use this document

1. Make sure that you know the structure and contents of this document.
2. Read the safety chapter and make sure that you know all the instructions.

3. Do the steps in the procedures fully and in the correct sequence.
4. Keep the document in a safe location that you can easily access. This document is a part of the EVSE.

1.9 General symbols and signal words

Signal word	Description	Symbol
Danger	If you do not obey the instruction, this can cause injury or death.	Refer to section 1.10.
Warning	If you do not obey the instruction, this can cause injury.	Refer to section 1.10.
Caution	If you do not obey the instruction, this can cause damage to the EVSE or to property.	
Note	A note gives more data, to make it easier to do the steps, for example.	
-	Information about the condition of the EVSE before you start the procedure.	
-	Requirements for personnel for a procedure.	
-	General safety instructions for a procedure.	
-	Information about spare parts that are necessary for a procedure.	
-	Information about support equipment that is necessary for a procedure.	
-	Information about supplies (consumables) that are necessary for a procedure.	
-	Make sure that the power supply to the EVSE is disconnected.	





Signal word	Description	Symbol
-	Electrotechnical expertise is required, according to the local rules.	
-	Alternating current supply	



Note: It is possible that not all symbols or signal words are present in this document.

1.10

Special symbols for warnings and dangers

Symbol	Risk type
	General risk
	Hazardous voltage that gives risk of electrocution
	Risk of pinching or crushing of body parts
	Rotating parts that can cause a risk of entrapment



Note: It is possible that not all symbols are present in this document.

1.11

Related documents

Document name	Target group
Product data sheet	All target groups
Installation manual	Qualified installation engineer
User manual	Owner
Declaration of conformity (CE)	All target groups

You can find all related documents here: <https://new.abb.com/ev-charging/terra-ac-wallbox>.

1.12 Manufacturer and contact data

Manufacturer

ABB EV Infrastructure
George Hintzenweg 81
3068 AX, Rotterdam
The Netherlands

Contact data

ABB EV Infrastructure in your country can give you support on the EVSE. You can find the contact data here: <https://new.abb.com/ev-charging>

1.13 Abbreviations

Abbreviation	Definition
AC	Alternating current
CAN	Controller area network
CPU	Central processing unit
DC	Direct current
EMC	Electromagnetic compatibility
EV	Electric vehicle
EVSE	Electric vehicle supply equipment
MID	Measuring Instruments Directive
NFC	Near field communication
NoBo	Notified body
OCPP	Open charge point protocol
PE	Protective earth
PPE	Personal protective equipment
RFID	Radio-frequency identification



Note: It is possible that not all abbreviations are present in this document.

1.14 Terminology

Term	Definition
Network operating center of the manufacturer	Facility of the manufacturer to do a remote check on the correct operation of the EVSE
Cabinet	Enclosure of the EVSE, including the components on the inside
Contractor	Third party that the owner or site operator hires to do engineering, civil and electrical installation work

Term	Definition
Grid provider	Company that is responsible for the transport and distribution of electricity
Local rules	All rules that apply to the EVSE during the entire lifecycle of the EVSE. The local rules also include the national laws and regulations.
Open charge point protocol	Open standard for communication with charge stations
Owner	Legal owner of the EVSE
Site operator	Entity that is responsible for the day-to-day control of the EVSE. The site operator does not have to be the owner.
User	Owner of an EV, who uses the EVSE to charge the EV



Note: It is possible that not all terms are present in this document.

1.15 Orientation agreements

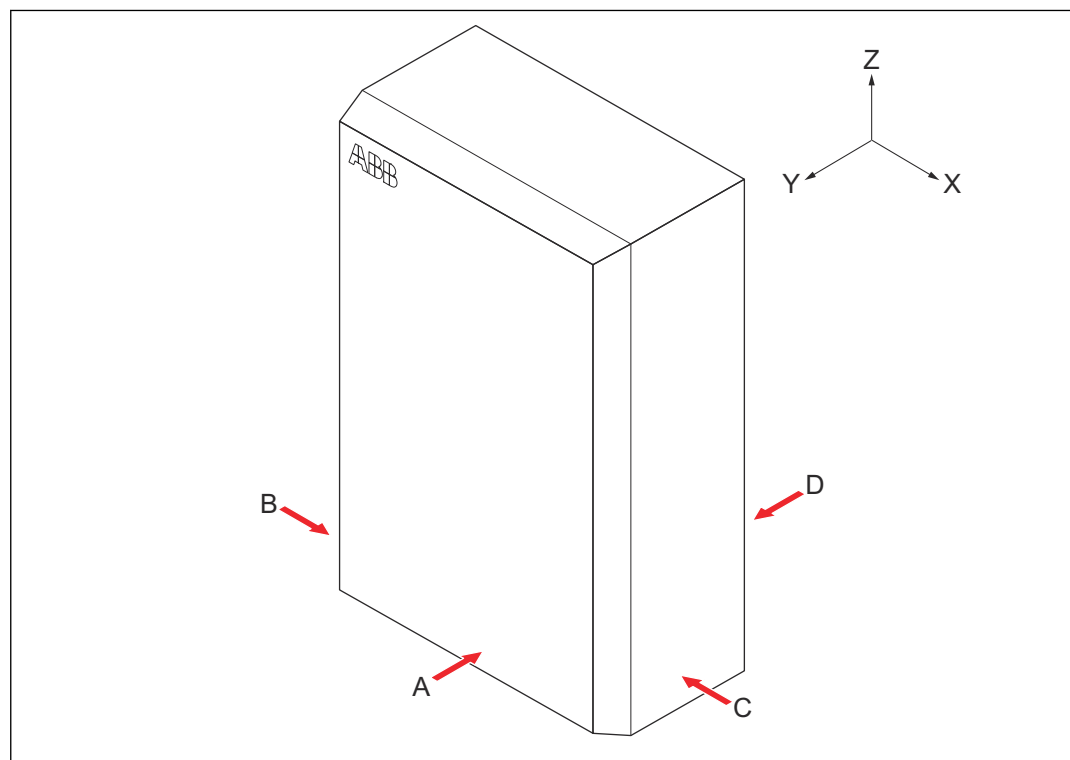

- | | | | |
|---|--|---|--|
| A | Front side: face forward to the EVSE during normal use | X | X-direction (positive is to the right) |
| B | Left side | Y | Y-direction (positive is rearward) |
| C | Right side | Z | Z-direction (positive is upward) |
| D | Rear side | | |

2 Description

2.1 Short description

The EVSE (Terra AC) is an AC charging station that you can use to supply electricity to an EV. The Terra AC offers tailor-made, intelligent and network charging solutions for your company or home. The EVSE can connect to the internet via GSM, WiFi or LAN.

2.2 Intended use

The EVSE is intended for the AC charging of EVs. The EVSE is intended for indoor or outdoor use.

The technical data of the EVSE must comply with the properties of the electrical grid, the ambient conditions and the EV. Refer to chapter 11.

Only use the EVSE with accessories that the manufacturer provides or that obey the local rules.

The EVSE AC input is intended for a hardwired installation that complies with the applicable national regulations.



Danger:

General risk

- If you use the EVSE in any other way than described in the related documents, you can cause death, injury and damage to property.
- Use the EVSE only as intended.

2.3 Product label (IEC portfolio)

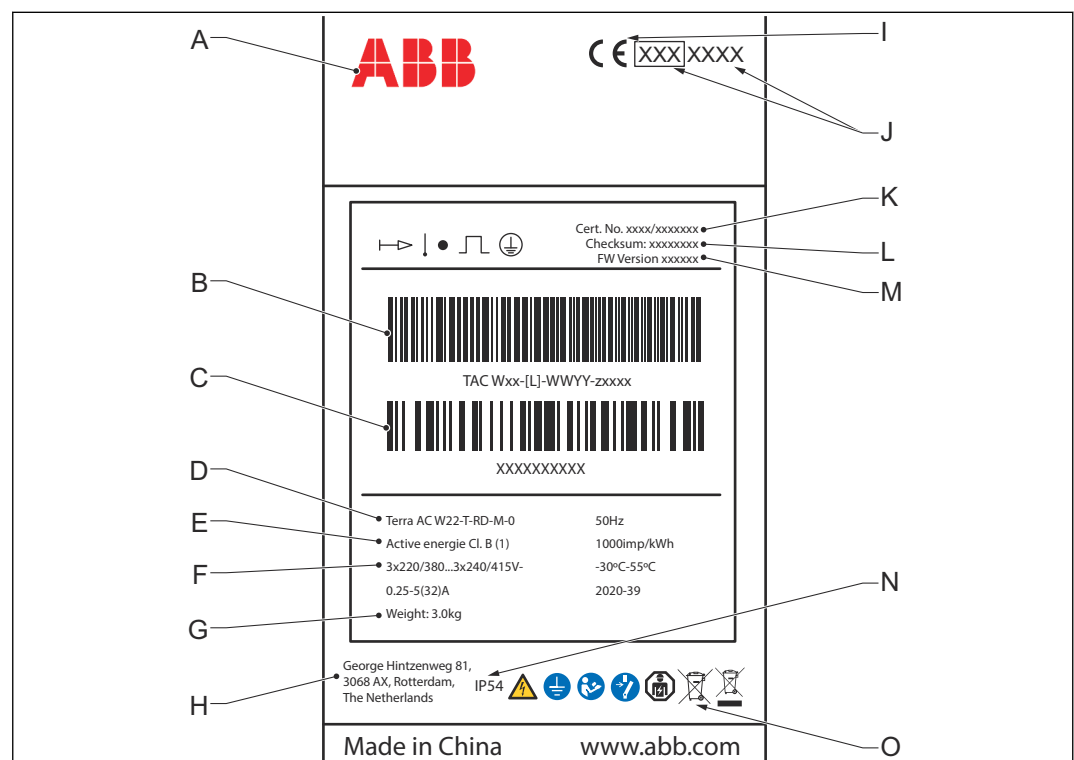

- | | | | |
|---|--|---|-----------------------------------|
| A | Brand | I | CE mark |
| B | Barcode with the serial number | J | MID mark and notified body number |
| C | Barcode with the part number of the EVSE | K | MID certificate number |
| D | Product model number | L | MID software checksum |
| E | MID accuracy class | M | MID FW version |
| F | EVSE rating | N | Ingress protection rating |
| G | Mass of the EVSE | O | Reference to the manual |
| H | Address of the manufacturer | | |



Note: The data in the illustration is only an example. Find the product label on your EVSE to see the applicable data. Refer to section 2.6.2.

2.4 Product label (UL portfolio)

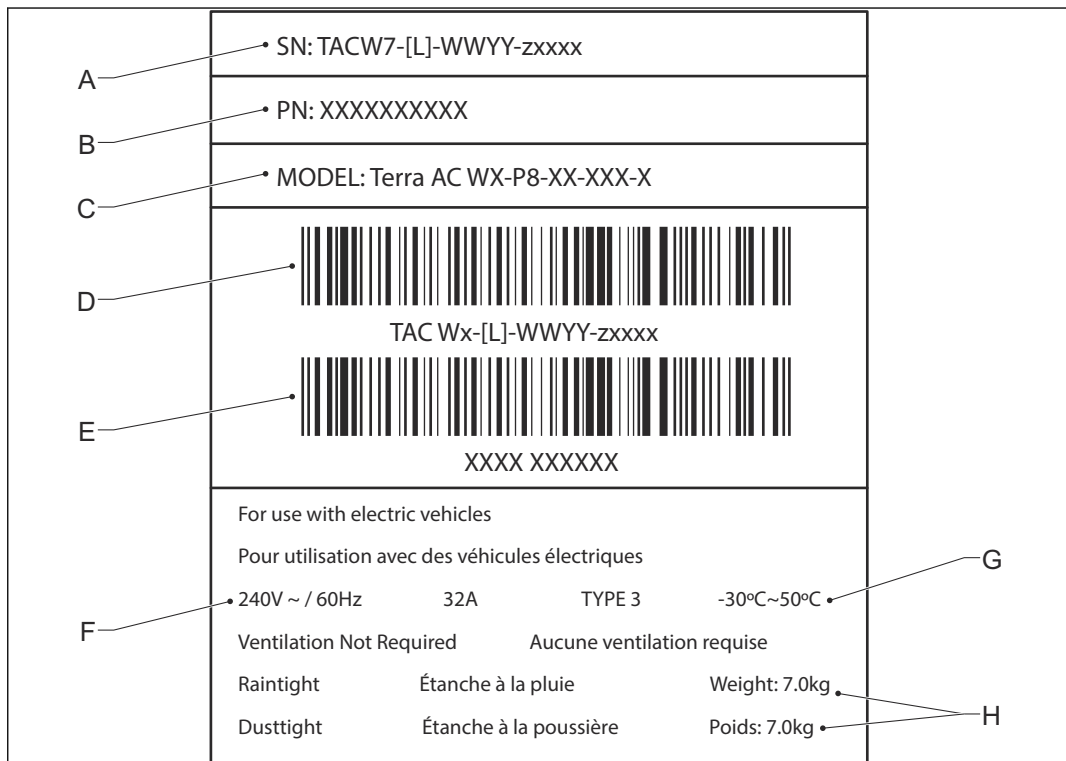

- | | | | |
|---|--|---|--|
| A | Serial number | E | Barcode with the part number of the EVSE |
| B | Part number of the EVSE | F | Power rating of the EVSE |
| C | Product model number | G | Ambient temperature |
| D | Barcode with the serial number of the EVSE | H | Mass of the EVSE |



Note: The data in the illustration is only an example. Find the product label on your EVSE to see the applicable data. Refer to section 2.6.2.

2.5 Working principle

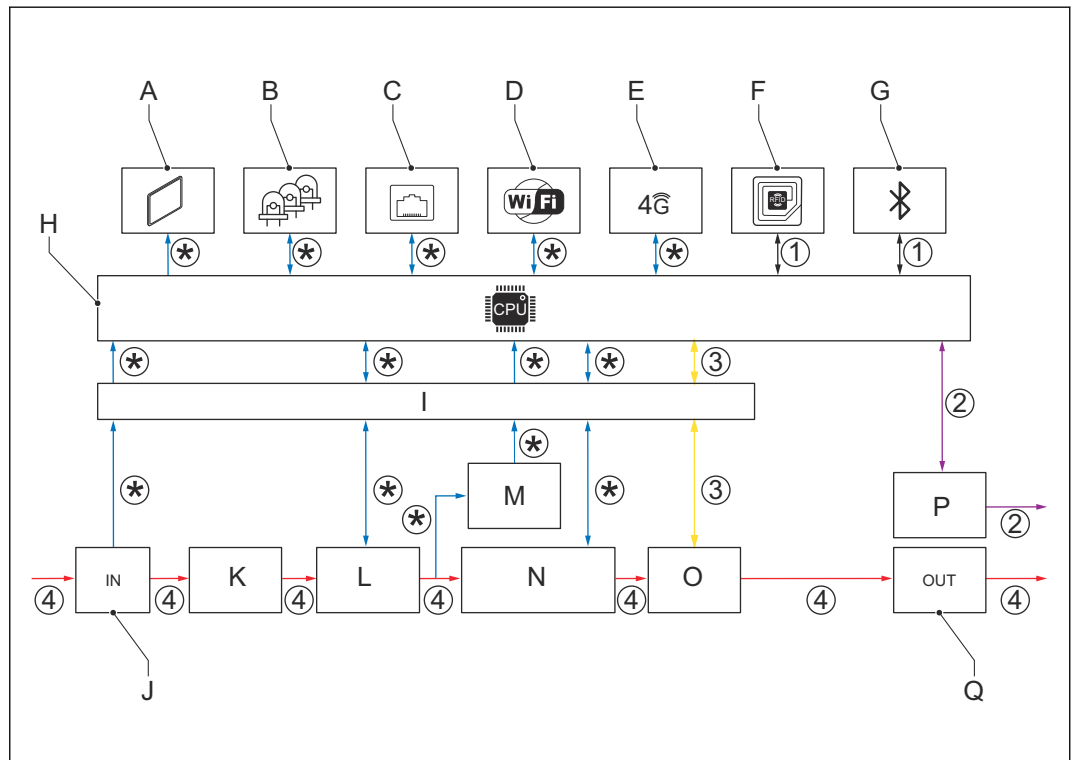

A	LEDs	I	AC/DC power supply
B	Ethernet	J	AC input
C	WiFi	K	Surge protection
D	4G	L	Earth(ground) fault protection
E	RFID	M	AC input metering
F	Bluetooth	N	AC isolation relay
G	CPU system	O	Control pilot
H	Isolation	P	AC output

1. The user initiates a charge session request (black lines).
2. The EVSE verifies the status of the EV (purple lines).
3. The EVSE goes on and AC power goes to the EV (yellow lines).
4. The charge session starts. AC power flows from the power grid to the EV (red lines).
5. The electrical interfaces of the EVSE communicate with the on-board computer (blue lines).

(*): Connections between parts of the EVSE and the CPU system. The arrow shows the direction of the input and output signals.

2.6 Overview

2.6.1 Overview of the system

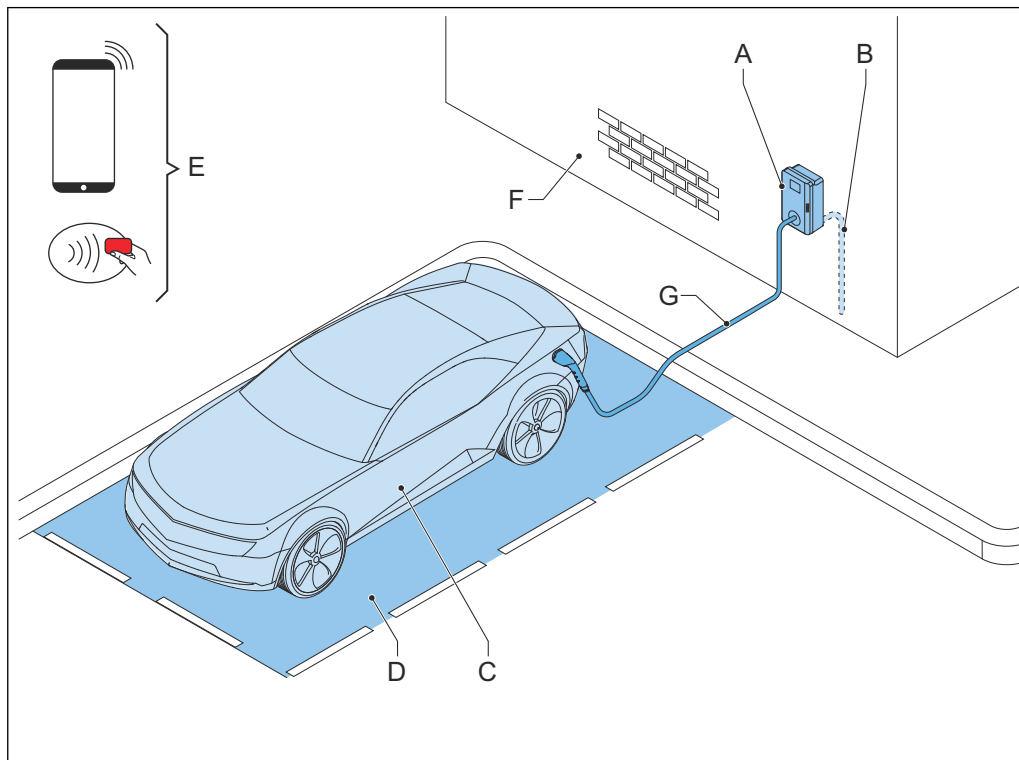

- | | | | |
|---|---------------|---|----------------------------------|
| A | EVSE | E | RFID card or smartphone |
| B | AC grid input | F | Structure to install the EVSE on |
| C | EV | G | EV charge cable |
| D | Parking space | | |

Part	Function
EVSE	Refer to section 2.2.
Structure	To install the EVSE on and to keep the EVSE in position.
AC grid input	To supply the electricity to the EVSE
EV charge cable	To conduct the current from the EVSE to the EV
EV	The EV of which the batteries need to be charged
Parking space	Location for the EV during the charge session
RFID card or smartphone	To authorize the user to use the EVSE

2.6.2 Overview of the EVSE, outside



Note: The illustration shows the EVSE model without a display.

Description

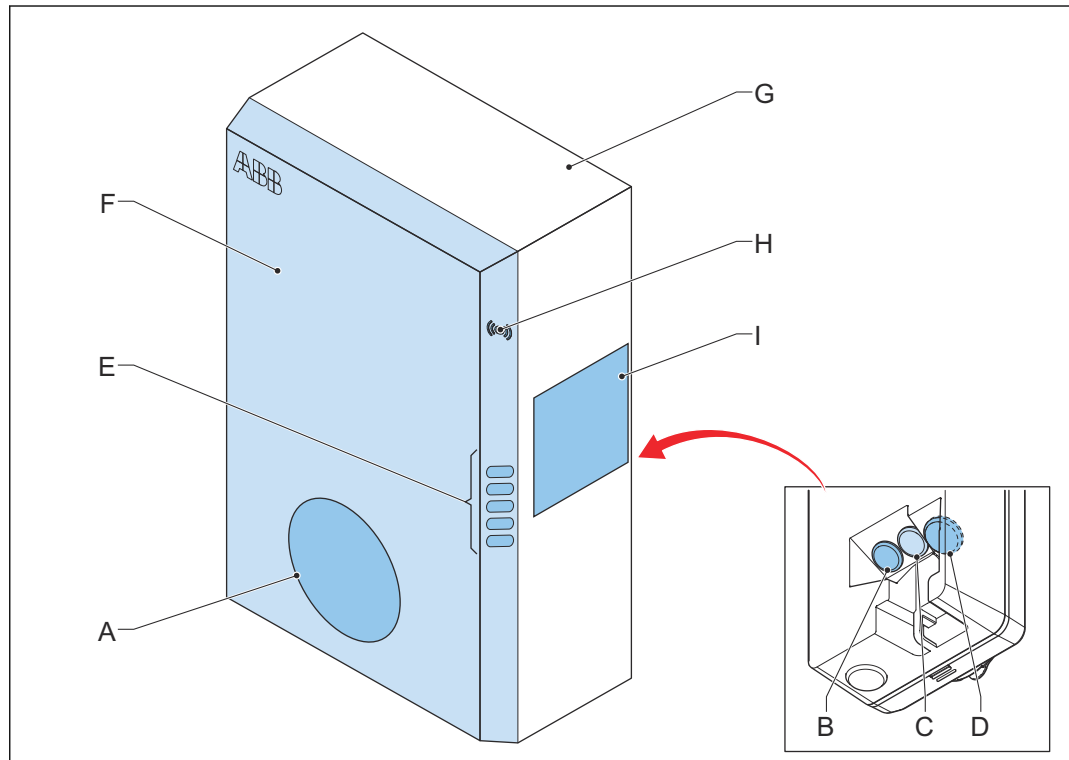

- | | | | |
|---|--|---|---------------|
| A | Connection for the EV charge cable | F | Cabinet cover |
| B | Openings for the smart meter connections | G | Enclosure |
| C | Opening for the Ethernet cable | H | RFID reader |
| D | Opening for the AC input cable | I | Product label |
| E | LED indicators | | |

Part	Function
Connection for the EV charge cable	To connect the EV charge cable
Openings	Openings for the cables that go into the EVSE
LED indicators	To show the status of the EVSE and the charge session. Refer to section 2.8.1.
Cabinet cover	To prevent a user to access the installation and maintenance parts of the EVSE
Enclosure	To reduce the accessibility of unqualified persons to the inside of the EVSE
RFID reader	To authorize the start or stop of a charging session with an RFID card
Product label	To show the identification data of the EVSE. Refer to section 2.3.

2.6.3

Overview of the EVSE, inside (CE model)

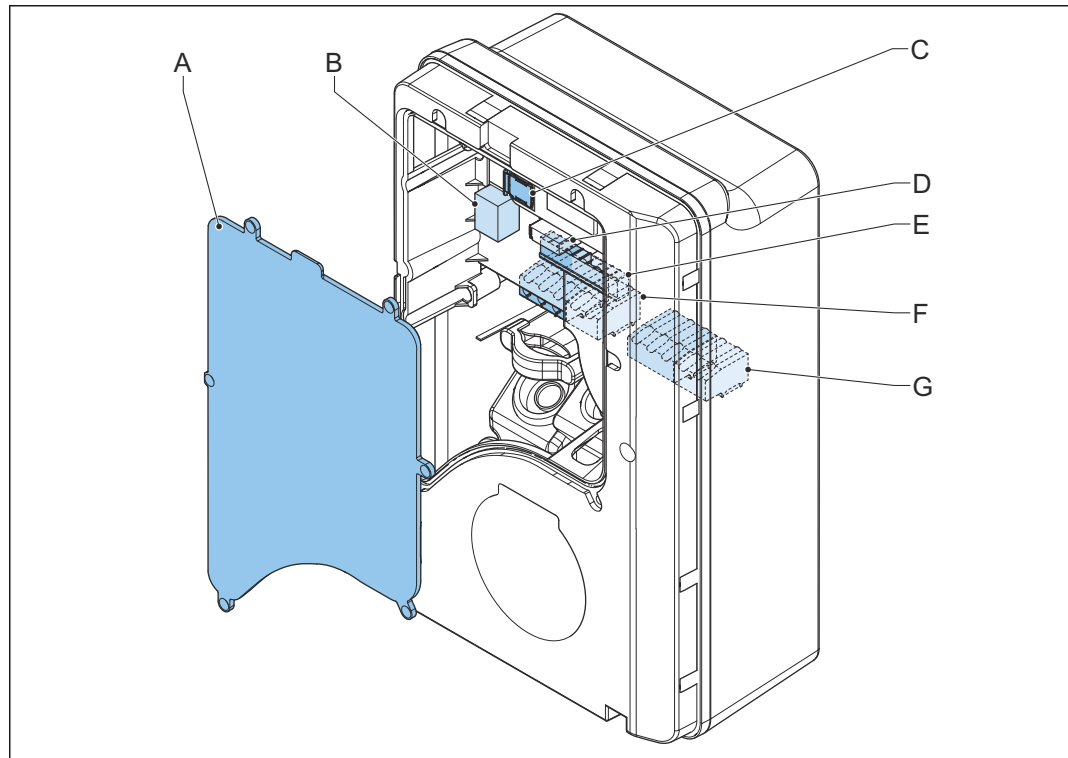

A	Maintenance cover	E	Terminal block for dry contacts input and output
B	Primary Ethernet connection	F	Terminal block for the AC input
C	Socket for a Nano-M2M SIM card	G	Terminal block for the EV charge cable or the socket
D	Smart meter connection		

Part	Function
Maintenance cover	To prevent access to the electrical components of the EVSE
Primary Ethernet connection	To connect the Ethernet cable
Socket for a Nano-M2M SIM card	To connect the EVSE to the internet 4G
Smart meter connection	To connect the cables for Modbus RTU - RS485
Terminal block for dry contacts input and output	Not used
Terminal block for the AC input	To connect the AC input cable from the grid
Terminal block for the EV charge cable	To connect the EV charge cable or the socket outlet

2.6.4 Overview of the EVSE, inside (MID model)

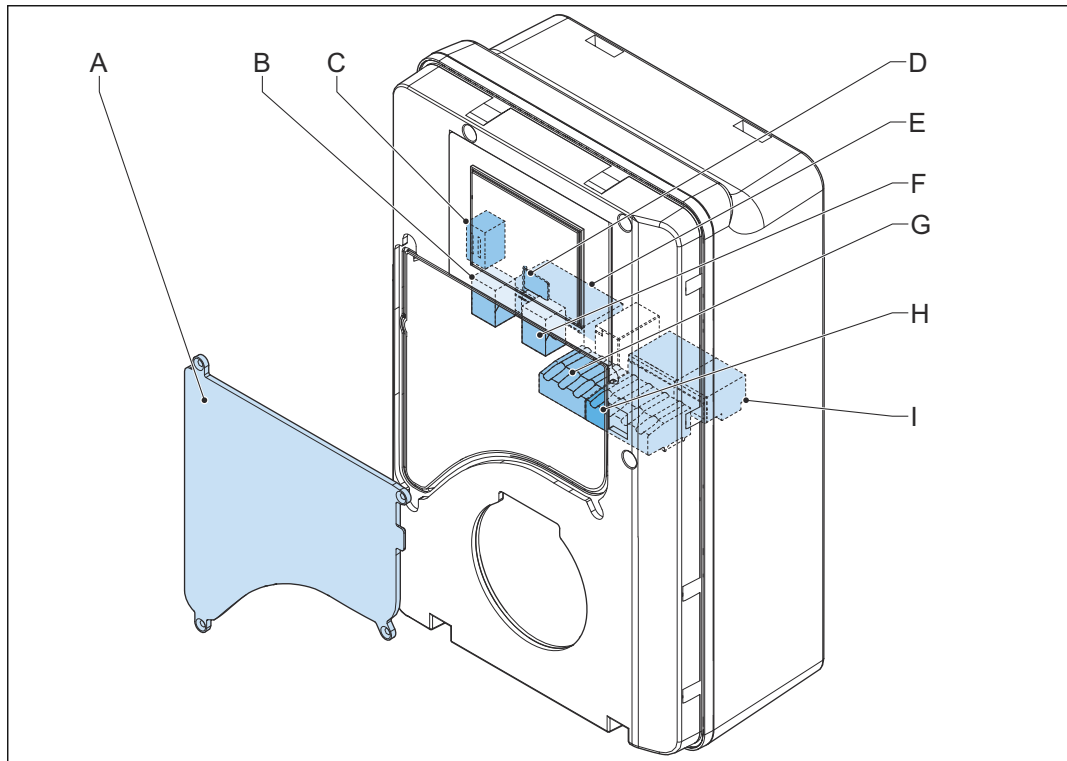

- | | | | |
|---|---------------------------------|---|--|
| A | Maintenance cover | F | Secondary Ethernet connection |
| B | Primary Ethernet connection | G | Smart meter connection |
| C | Electrical pulse connector | H | Terminal block for dry contacts input and output |
| D | Socket for a Nano-M2M SIM card | I | Terminal block for the EV charge cable or the socket |
| E | Terminal block for the AC input | | |

Part	Function
Maintenance cover	To prevent access to the electrical components of the EVSE
Primary Ethernet connection	To connect the Ethernet cable
Electrical pulse connector	Use for manufacturer only. Do not change or connect cables to this input yourself.
Socket for a Nano-M2M SIM card	To connect the EVSE to the internet 4G
Terminal block for the AC input	To connect the AC input cable from the grid
Secondary Ethernet connection	To use one Ethernet cable connection for multiple EVSEs. There is no communication between the EVSEs.
Smart meter connection	To connect the cables for Modbus RTU - RS485
Terminal block for dry contacts input and output	Not used
Terminal block for the EV charge cable	To connect the EV charge cable or the socket outlet

2.6.5

Overview of the EVSE, inside (UL model)

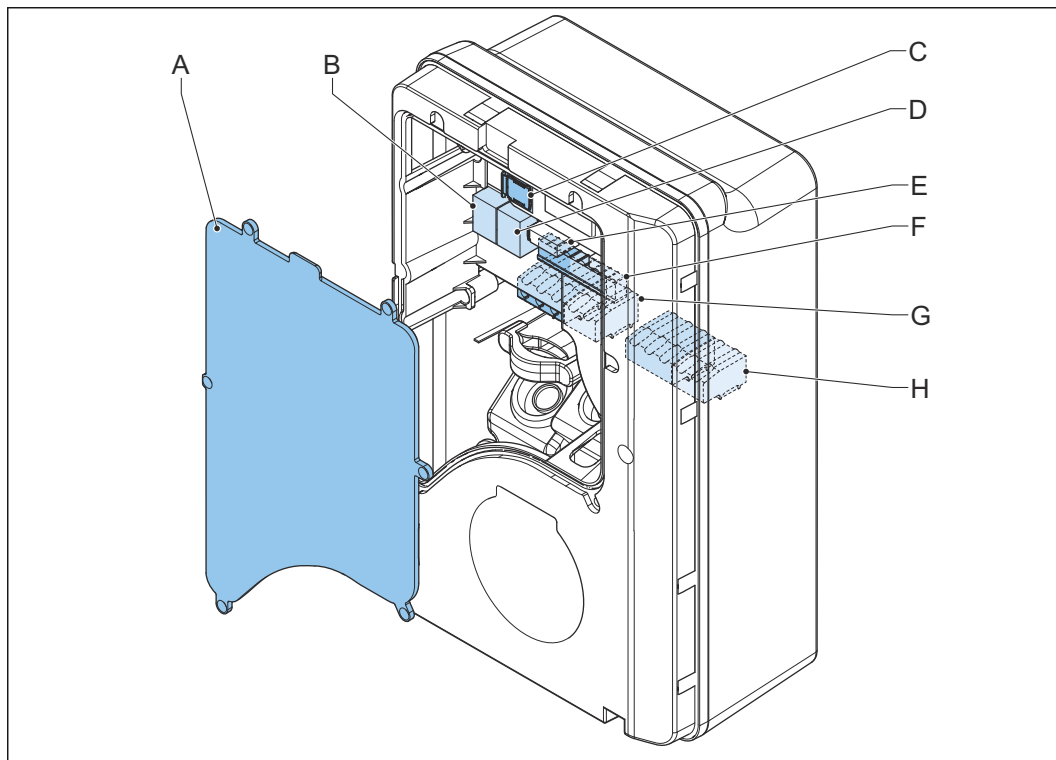

A	Maintenance cover	E	Smart meter connection
B	Primary Ethernet connection	F	Terminal block for dry contacts input and output
C	Socket for a Nano-M2M SIM card	G	Terminal block for the AC input
D	Secondary Ethernet connection	H	Terminal block for the EV charge cable or the socket

Part	Function
Maintenance cover	To prevent access to the electrical components of the EVSE
Primary Ethernet connection	To connect the Ethernet cable
Socket for a Nano-M2M SIM card	To connect the EVSE to the internet 4G
Secondary Ethernet connection	To use one Ethernet cable connection for multiple EVSEs. There is no communication between the EVSEs.
Smart meter connection	To connect the cables for Modbus RTU - RS485
Terminal block for dry contacts input and output	Not used
Terminal block for the AC input	To connect the AC input cable from the grid
Terminal block for the EV charge cable or the socket	To connect the EV charge cable or the socket outlet

2.6.6 Overview of the EVSE, inside (UL model with display)

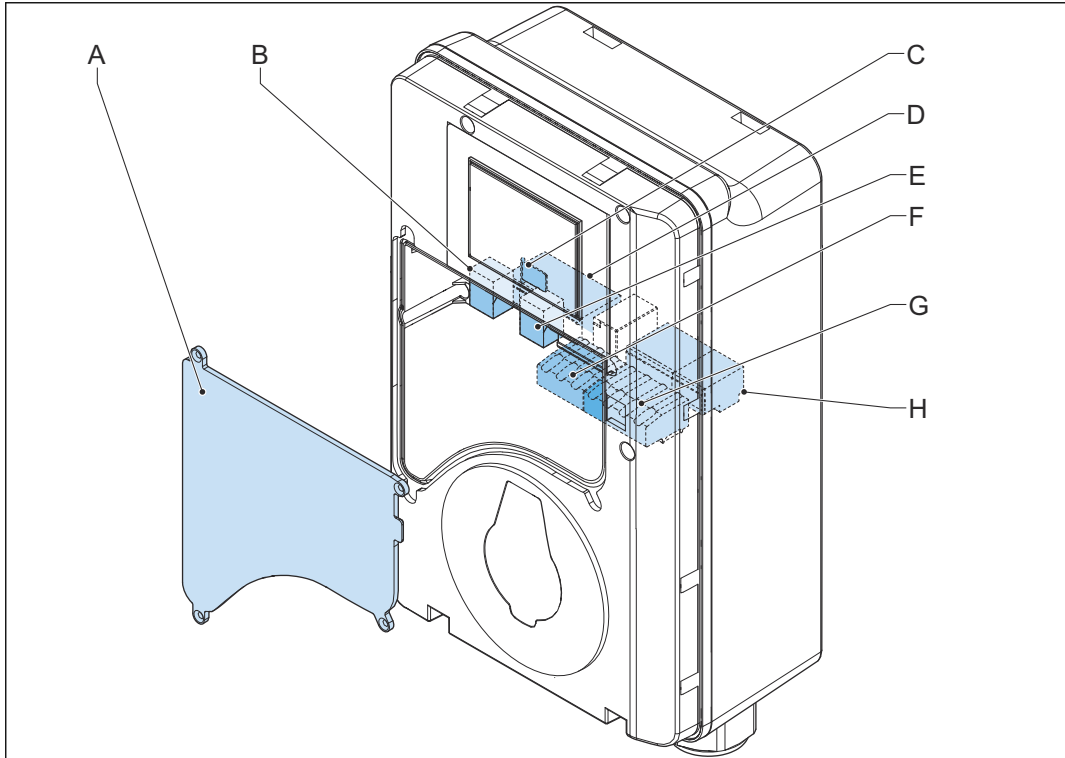

- | | | | |
|---|---------------------------------|---|--|
| A | Maintenance cover | E | Secondary Ethernet connection |
| B | Primary Ethernet connection | F | Smart meter connection |
| C | Socket for a Nano-M2M SIM card | G | Terminal block for dry contacts input and output |
| D | Terminal block for the AC input | H | Terminal block for the EV charge cable or the socket |

Part	Function
Maintenance cover	To prevent access to the electrical components of the EVSE
Primary Ethernet connection	To connect the Ethernet cable
Socket for a Nano-M2M SIM card	To connect the EVSE to the internet 4G
Terminal block for the AC input	To connect the AC input cable from the grid
Secondary Ethernet connection	To use one Ethernet cable connection for multiple EVSEs. There is no communication between the EVSEs.
Smart meter connection	To connect the cables for Modbus RTU - RS485
Terminal block for dry contacts input and output	Not used
Terminal block for the EV charge cable or the socket	To connect the EV charge cable or the socket outlet

2.7 Options

2.7.1 Display

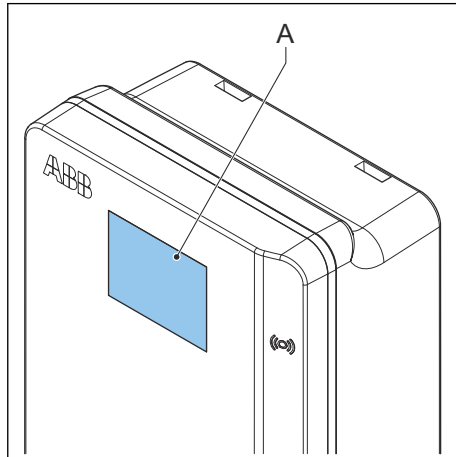

A Display

For more data about the display, refer to section 2.10.

2.7.2 EV charge cable, Type 2

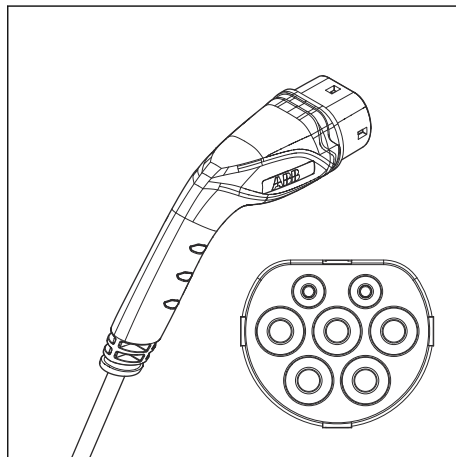

2.7.3 Socket, Type 2

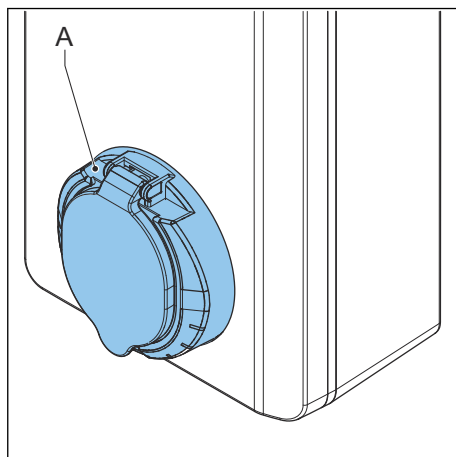

A Socket

The socket for an EV charge cable Type 2 is available with or without a shutter.

2.7.4 EV charge cable, Type 1 (UL portfolio)

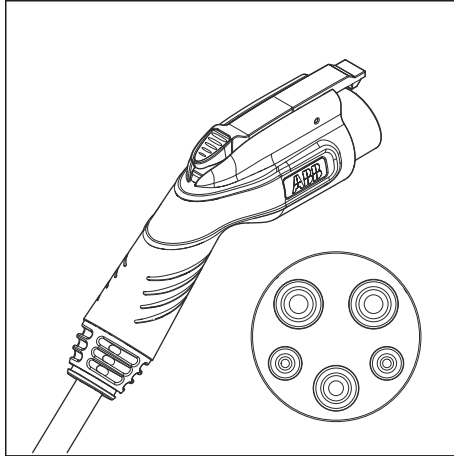

2.7.5 4G Communication

You can connect to a 4G network.

2.7.6 Load management

Load management makes sure that the available electrical capacity of the building or home is not exceeded. A number of devices share a grid connection, that has a maximum capacity. The total power demand of the devices that use the grid connection must not exceed the grid capacity.

The load management feature prevents that the system exceeds the grid capacity and prevents damage of the fuses. At times when the current demand is high, the EVSE decreases the output of current. The current will increase again when there is availability on the grid.

Also, the load management feature makes sure that the available load is optimally shared.

2.8 Control elements

2.8.1 LED indicators

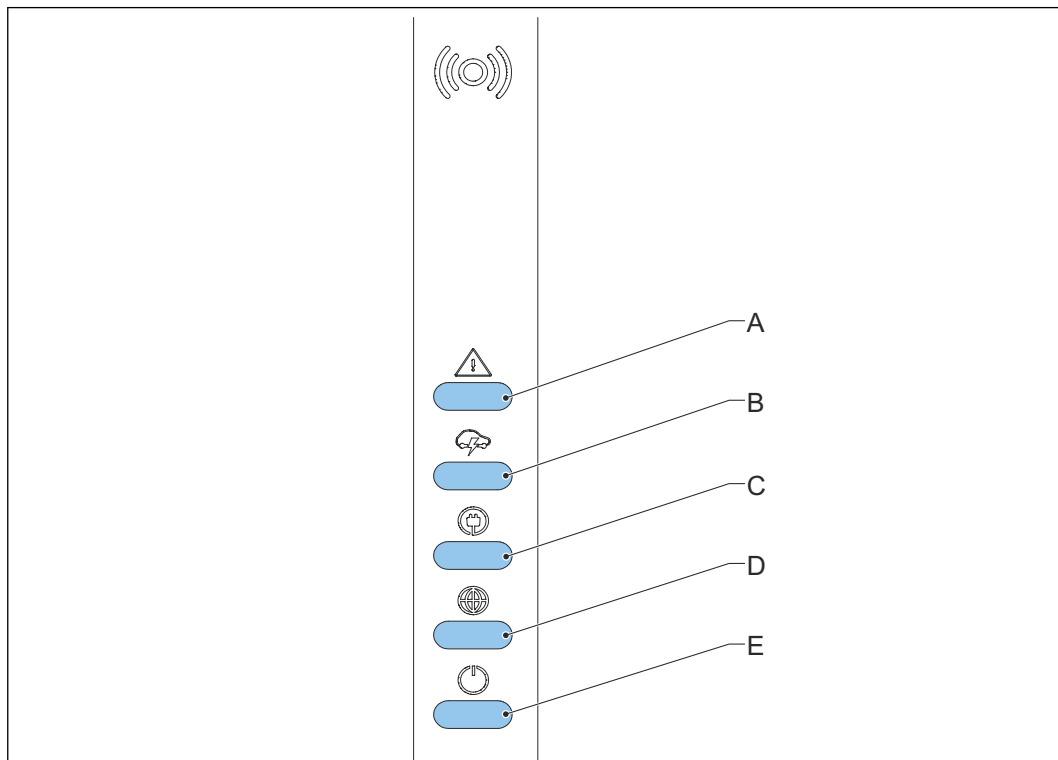

- | | | | |
|---|--|---|-------------------------|
| A | Error LED | D | Internet connection LED |
| B | Charging LED | E | EVSE on/off LED |
| C | Cable and EV detection, and EV authorization LED | | |

Table 1: Error LED

Status of the LED	Status of the EVSE
On	Error
Off	No error

Table 2: Charging LED

Status of the LED	Status of the EVSE
On	EV is fully charged or has stopped charging
Off	Not charging
Flashing	Charging

Table 3: Cable and EV detection, and EV authorization LED

Status of the LED	Status of the EVSE
On	An EV is connected. The connection is authorized.
Off	No EV connected
Flashing	A EV is connected, waiting for authorization

Table 4: Internet connection LED

Status of the LED	Status of the EVSE
On	Connected to the internet
Off	Not connected to the internet
Flashing	In progress to establish internet connection

Table 5: EVSE on/off LED

Status of the LED	Status of the EVSE
On	The EVSE is on
Off	The EVSE is off
Flashing	The EVSE is in setup

2.9 TerraConfig app to do the commissioning

The *TerraConfig* app is available on the *Apple Store* and on the *Google Play Store*. The app is necessary to do the commissioning.

2.10 Description of the display screens (option)

2.10.1 Boot screen

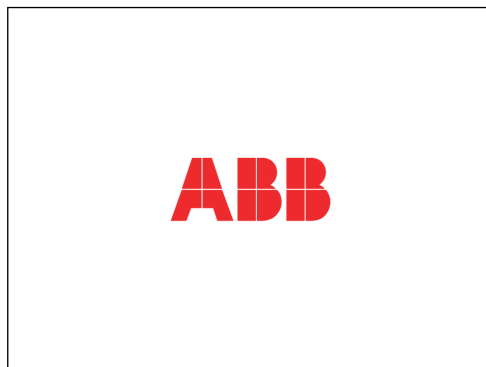

During the start up of the EVSE, the display shows the Boot screen.

2.10.2 Standby/Idle screen

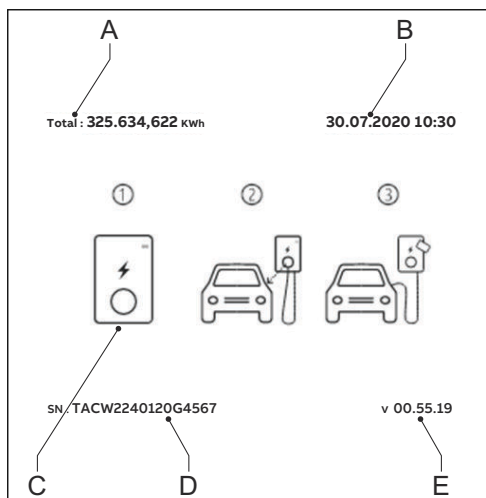

- A Total delivered energy
- B Date
- C Guide
- D Serial number
- E Firmware version (MID certified)

The display shows the Standby/Idle screen when the EVSE is in idle status. Then, the EVSE is available for a charge session.

2.10.3 Authorization screen

The display shows different Authorization screens, dependent on the situation.

The display shows this Authorization screen when the EV charge cable is connected to the EV but the charge session is not authorized:

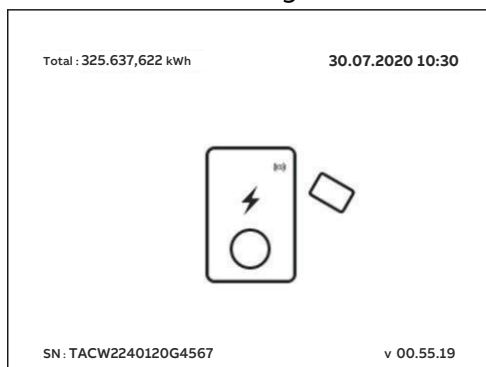

The display shows this Authorization screen when the charge session is authorized but the EV charge cable is not connected to the EV:

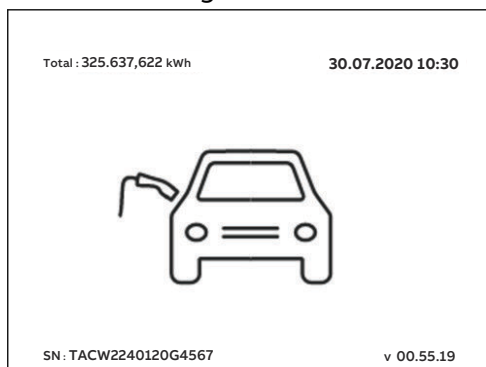

2.10.4 Preparing to charge screen

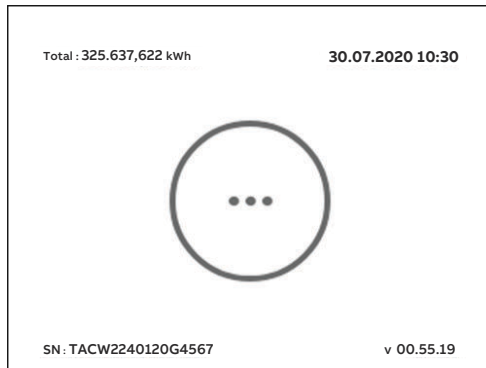

2.10.5 Charging screen

The display shows the Charging screen during the charge session.

The display shows this Charging screen for a single phase EVSE:

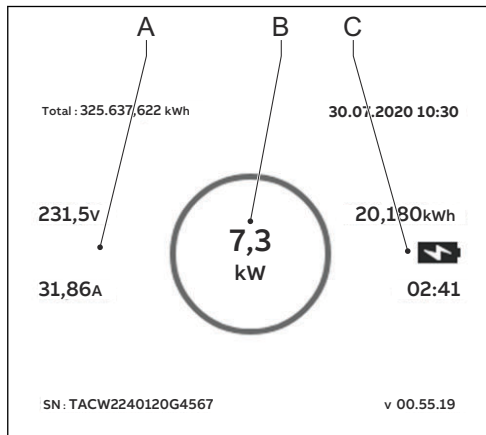

A Real-time voltage and current

B Real-time active power

C Energy delivered and duration of the charge session

The display shows this Charging screen for a 3 phase EVSE:

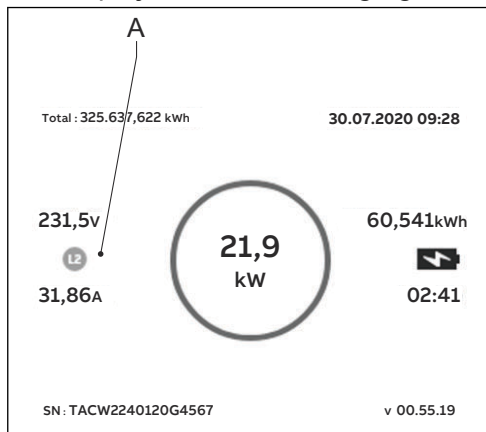

A Real-time voltage and current per phase

2.10.6 Charging completed screen

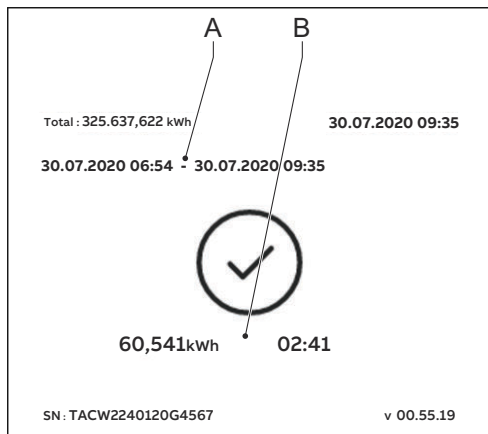

A Start and end time

B Energy delivered and duration of the charge session

2.10.7 Fault detected display messages

The display shows different fault detected images, dependent on the type of fault.

Disconnect the charge cable and connect it again:

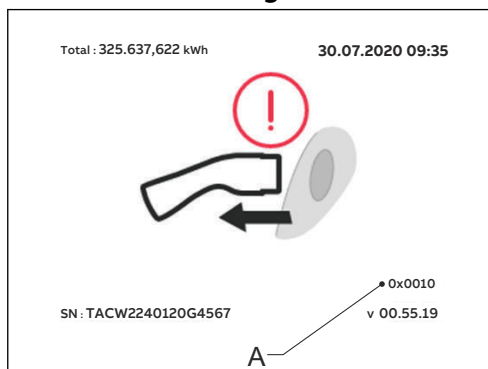

A Error code

Contact your service provider:

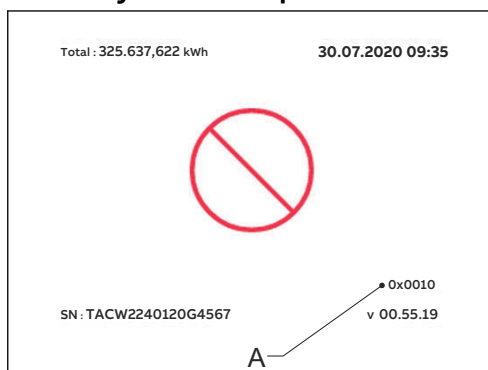

A Error code

Description

The EV is not ready for the charge session:

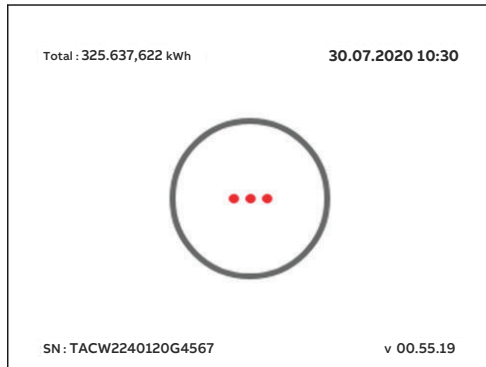

3 Safety

3.1 Liability

The manufacturer is not liable to the purchaser of the EVSE or to third parties for damages, losses, costs or expenses incurred by the purchaser or third parties if any target group mentioned in the related documents does not obey the rules below:

- Obey the instructions in the related documents. Refer to section 1.11.
- Do not misuse or abuse the EVSE.
- Only make changes to the EVSE, if the manufacturer approves in writing of the changes.

This EVSE is designed to be connected to and to communicate information and data via a network interface. It is the sole responsibility of the owner to provide and continuously ensure a secure connection between the EVSE and the network of the owner or any other network.

The owner shall establish and maintain any appropriate measures (such as - but not limited to - the installation of firewalls, application of authentication measures, encryption of data and installation of anti-virus programs) to protect the EVSE, the network, its system and the interface against any kind of security breaches, unauthorized access, interference, intrusion, leakage and/or theft of data or information.



The manufacturer is not liable for damages and/or losses related to such security breaches, any unauthorized access, interference, intrusion, leakage and/or theft of data or information.



3.2 Required qualifications for the installation engineer



- The qualified installation engineer fully knows the EVSE and its safe installation.
- The installation engineer is qualified according to the applicable local rules to do the work.
- The qualified installation engineer obeys all local rules and the instructions in the installation manual.
- It is the responsibility of the owner of the EVSE to make sure that all qualified installation engineers obey the local rules, the installation instructions, and the specifications of the EVSE.

3.3 Personal protective equipment

Symbol	Description
	Protective clothing
	Safety gloves

Symbol	Description
	Safety shoes
	Safety glasses

3.4 FCC compliance statement



Caution: Changes or modifications not expressly approved by the party responsible for compliance could void the user's authority to operate the equipment.



Note: This equipment has been tested and found to comply with the limits for a Class B digital device, pursuant to part 15 of the FCC Rules. These limits are designed to provide reasonable protection against harmful interference in a residential installation. This equipment generates, uses and can radiate radio frequency energy and, if not installed and used in accordance with the instructions, may cause harmful interference to radio communications. However, there is no guarantee that interference will not occur in a particular installation. If this equipment does cause harmful interference to radio or television reception, which can be determined by turning the equipment off and on, the user is encouraged to try to correct the interference by one or more of the following measures:

- Reorient or relocate the receiving antenna.
- Increase the separation between the equipment and receiver.
- Connect the equipment into an outlet on a circuit different from that to which the receiver is connected.
- Consult the dealer or an experienced radio/TV technician for help.

3.5 Industry Canada compliance statement

This device contains licence-exempt transmitter(s)/receiver(s) that comply with Innovation, Science and Economic Development Canada's licence-exempt RSS(s). Operation is subject to the following two conditions:

- This device may not cause interference.
- This device must accept any interference, including interference that may cause undesired operation of the device.

RF exposure statement







This equipment complies with IC radiation exposure limits set forth for an uncontrolled environment. This equipment should be installed and operated with minimum distance 20cm between the radiator and your body.

3.6 General safety instructions

- This document, the related documents and the warnings included do not replace your responsibility to use your common sense when you do work on the EVSE.
- Only do the procedures that the related documents show and that you are qualified for.
- Obey the local rules and the instructions in this manual. If the local rules contradict the instructions in this manual, the local rules will apply.

If and to the extent permitted by law, in case of inconsistency or contradiction, between any requirements or procedure contained in this document and any such local rules, obey the stricter between the requirements and procedures specified in this document and the local rules.

3.7 Signs on the EVSE

Symbol	Risk type
	General risk
	Hazardous voltage that gives risk of electrocution
	Risk of pinching or crushing of body parts
	Rotating parts can cause a risk of entrapment
	PE
	Sign that means that you must read the manual before you install the EVSE
	Waste from electrical and electronic equipment



Note: It is possible that not all symbols are present on the EVSE.

3.8 Discard the EVSE or parts of the EVSE

Incorrect waste handling can have a negative effect on the environment and human health due to potential hazardous substances. With the correct disposal of this product, you contribute to reuse and recycling of materials and protection of the environment.

- Obey the local rules to discard parts, packaging material or the EVSE.
- Discard electrical and electronic equipment separately in compliance with the WEEE - 2012/19/EU Directive on waste of electrical and electronic equipment.
- As the symbol of the crossed out wheeled-bin on your EVSE indicates, do not mix or dispose the EVSE with your household waste, at the end of use. Instead, hand the EVSE over to your local community waste collection point for recycling.
- For more information, contact the Government Waste-Disposal department in your country.

3.9 Safety instructions for earthing

Preliminary requirements

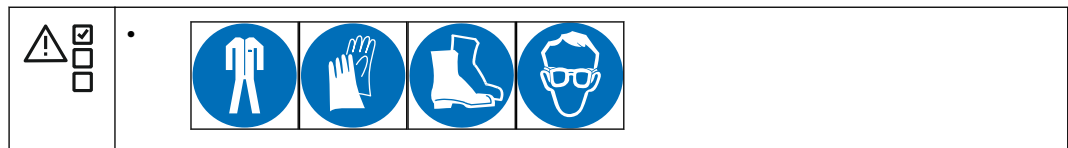

- Make sure that the EVSE is connected to a grounded, metal, permanent wiring system, or an equipment-grounding conductor must be run with the circuit conductors and connected to the equipment grounding terminal or lead on the product.
- Make sure that the connections to the EVSE comply with all applicable local rules.

3.10 Special safety instructions (IEC portfolio)

3.10.1 Safety instructions during installation

Preliminary requirements

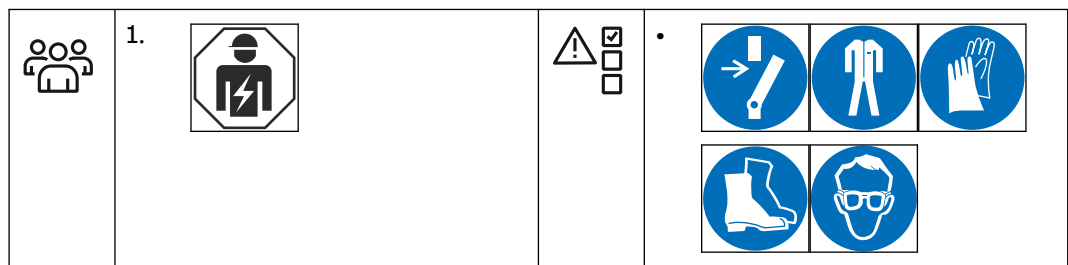

- Make sure that there is no voltage on the AC input cables during the complete installation procedure.
- Keep unqualified personnel at a safe distance during installation.
- Only use electrical wires of sufficient gauge and insulation to handle the rated current and voltage demand.
- Make sure that the load capacity of the grid is in accordance with the EVSE.

- Earth the EVSE correctly. Refer to section 3.9.
- Make sure that the wiring inside the EVSE is protected from damage and cannot get trapped when you open or close the cabinet.
- Make sure that water cannot enter the cabinet.
- Protect the EVSE with safety devices and measures that the local rules specify.
- If it is necessary to remove safety devices, immediately install the safety devices after the work.
- Put on the correct personal protective equipment. Refer to section 3.3.

3.11 Special safety instructions (UL portfolio)

3.11.1 Additional important safety instructions



Warning: Obey the basic precautions for electric products, including the instructions in this section.



Caution: To reduce the risk of fire, connect this EVSE only to a circuit provided with 40 A maximum branch circuit overcurrent protection in accordance with the National Electrical Code, ANSI/NFPA 70.



- Read all the instructions before you use this EVSE.
- Make sure that adults supervise this EVSE is when it is used around children.
- Do not put fingers into the EV connector.
- Do not use this product if the flexible power cord or EV charge cable is frayed, has broken insulation, or any other signs of damage.
- Do not use this EVSE if the enclosure or the EV connector is broken, cracked, open, or shows any other indication of damage.
- Install an insulated grounding conductor that is identical in size, insulation material, and thickness to the grounded and ungrounded branch-circuit supply conductors, except that it is green with or without one or more yellow stripes, as part of the branch circuit that supplies the EVSE.
- Connect the grounding connector of the previous bullet point to earth at the EVSE or, when supplied by a separately derived system, at the supply transformer.
- For the AC power input wiring installation, refer to section 11.11.4.
- For the torque requirements for the screws of the terminal block for the AC power, refer to section 11.15.

SAVE THESE INSTRUCTIONS

4 Installation

4.1 General installation procedure

Preliminary requirements

	<ol style="list-style-type: none"> 1. All required permits to agree with the local rules are granted. 2. The AC input cable is available. 		<ul style="list-style-type: none"> • There is no voltage on the AC input cable during the complete installation procedure.
	<ul style="list-style-type: none"> • Tools for installation. Refer to section 11.7. 		

Procedure

1. Unpack the EVSE. Refer to section 4.2.
2. Prepare the site. Refer to chapter 5.
3. Remove the cabinet cover. Refer to section 9.1.
4. Do the mechanical installation. Refer to section 6.1.
5. Do the electrical installation. Refer to section 7.1.
6. Install the cabinet cover. Refer to section 9.2.
7. Do the commissioning procedure. Refer to section 8.1.

4.2 Unpack the EVSE

1. Open the box.
2. Remove the EVSE from the box.
3. Remove all packaging material from the EVSE.
4. Discard the packaging material. Refer to section 3.8.
5. Make sure that all parts are delivered according to the order. Refer to the order and section 11.6.
6. Do an inspection of the EVSE and the parts for installation for damage.
7. If you find damage or the parts are not according to the order, contact the local representative of the manufacturer (ABB EV Infrastructure). Refer to section 1.12.

5 Site preparation

5.1 Select the site

1. Find a suitable site on a wall. For the specifications of the wall, refer to section 11.8.
2. Make sure that the correct power supply is available. For the power supply specifications, refer to section 11.11.
3. Obey the space requirements. Refer to section 11.10.3.

5.2 Prepare the site (IEC portfolio)

Preliminary requirements

	1. The site must be suitable to install the EVSE. Refer to section 5.1.
---	---



Note:

Information for MID certified EVSE:

- The meter is intended to be installed in a Mechanical Environment 'M1', with Shock and Vibrations of low significance, as per 2014/32/EU Directive.
- The meter is intended to be installed in Electromagnetic Environment 'E2', as per 2014/32/EU Directive.

Procedure

1. Make sure that the space and the airflow around the EVSE are sufficient. Refer to section 11.10.3.
2. Make sure that the correct cables are available at the site.
 - AC input cable. Refer to section 11.13.
 - RS485 cable. Refer to section 11.13.4.
 - Ethernet cable. Refer to section 11.13.3.

5.3 Prepare the site (UL portfolio)

Preliminary requirements

	1. The site must be suitable to install the EVSE. Refer to section 5.2.
---	---

Procedure

1. Make sure that the space and the airflow around the EVSE are sufficient. Refer to section 11.10.3.
2. Make sure that the correct cables are available at the site.
 - AC input cable. Refer to section 11.13.2.
 - RS485 cable. Refer to section 11.13.4.
 - Ethernet cable. Refer to section 11.13.3.

6 Mechanical installation

6.1 General mechanical installation procedure





Note: The mounting screws and plugs that are included in the delivery are serviceable for a brick wall. If you want to mount the EVSE on a different type of wall, contact your local representative of the manufacturer (ABB EV Infrastructure).

1. Prepare the holes for the mounting screws. Refer to section 6.2.
2. Install the upper mounting screws. Refer to section 6.3.
3. Install the EVSE on the site. Refer to section 6.4.

6.2 Prepare the holes for the mounting screws

Preliminary requirements

	<ul style="list-style-type: none"> • Spirit level • Drill 		<ul style="list-style-type: none"> • Installation template. Refer to section 11.6. • Plugs for the upper mounting holes. Refer to section 11.6 • Plugs for the lower mounting holes. Refer to section 11.6.
---	---	---	--

Procedure

1. Hold the installation template (A) against the wall.
2. Make sure that the installation is level. Use the spirit level.
3. Mark the location for the mounting holes (B) and (C).
4. Drill the upper mounting holes (B) and the lower mounting holes (C).



Note: For the diameter of the holes, refer to the plugs for the upper and lower mounting holes.

5. Insert the plugs for the upper mounting holes (D) in the upper mounting holes.
6. Insert the plugs for the lower mounting holes (E) in the lower mounting holes

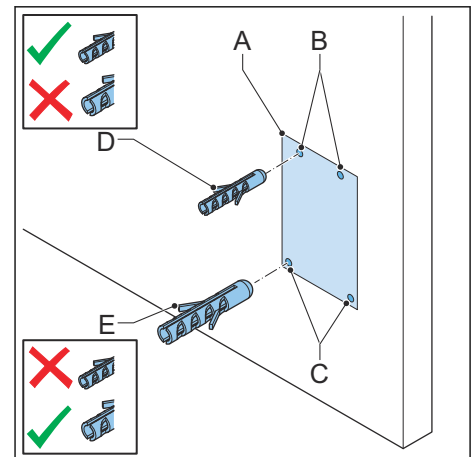

6.3 Install the upper mounting screws

Preliminary requirements

	<p>1. The plugs for the upper and lower mounting screws are installed.</p>		<ul style="list-style-type: none"> Upper mounting screws. Refer to section 11.6.
---	--	---	---

Procedure

1. Install the upper mounting screws (A) in the upper holes (B).
2. Make sure that a length (X) of the screws stays out of the wall. For the specification, refer to section 11.8. This length outside the wall is necessary to suspend the EVSE.

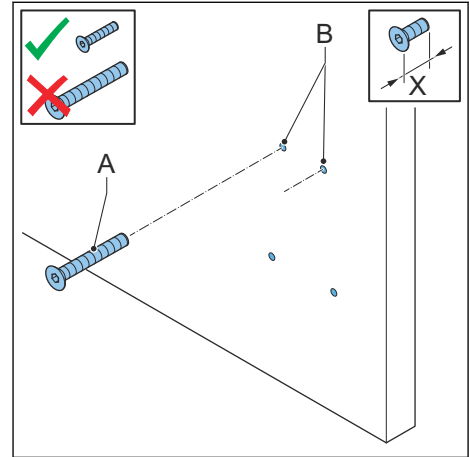

6.4 Install the EVSE on the wall

Preliminary requirements

	<p>1. The upper mounting screws are installed.</p>		<ul style="list-style-type: none"> Lower mounting screws. Refer to section 11.6.
---	--	---	---

Procedure

1. Put the openings (A) over the upper mounting screws (B). The upper mounting screws support the EVSE.
2. Install the lower mounting screws (C). For the torque specifications, refer to section 11.15.

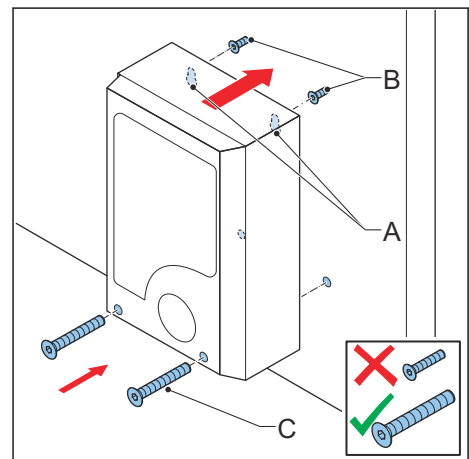

7 Electrical installation

7.1 General electrical installation procedure

Preliminary requirements





Procedure

1. Remove the maintenance cover. Refer to section 9.3.
2. Install the AC input cable.
 - Insert the AC input cable. Refer to section 7.2.
 - Connect the AC input cable. Refer to section 7.3.
3. Install the Ethernet cable.
 - Insert the Ethernet cable. Refer to section 7.4.1.
 - Connect the Ethernet cable. Refer to section 7.4.2.
4. If necessary, install the cables for smart meter communication.
 - Insert the cables for smart meter communication. Refer to section 7.4.3.
 - Connect the cables for smart meter communication. Refer to section 7.4.4.
5. If you want to use the internet, insert the Nano-M2M SIM card. Refer to section 7.4.5.
6. If necessary, replace the EV charge cable. Refer to section 7.5.
7. Install the maintenance cover. Refer to section 9.4.

7.2 Insert the AC input cable

Preliminary requirements

	<ul style="list-style-type: none"> • Screwdriver 		<ul style="list-style-type: none"> • AC input cable
---	---	---	--

Procedure

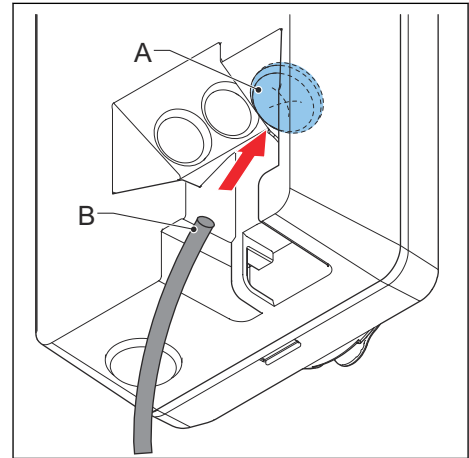

1. Remove the grommet (A) from the EVSE.
2. Make a hole in the center of the grommet.
3. Install the grommet.
4. Strip the wires. For the specification, refer to section 11.13.
5. Push the wires through the grommet.
6. Put the AC input cable (B) through the inlet hole.



7.3 Connect the AC input cable

7.3.1 Connect the AC input cable, 1 phase (IEC portfolio)

Preliminary requirements

	<ul style="list-style-type: none"> • Torque screwdriver 		<ul style="list-style-type: none"> • AC input cable (1 phase)
---	--	---	--

Procedure

1. Loosen the screws (A).
2. Strip the wires. For the specification, refer to section 11.13.1.
3. Insert the cable connector into the terminal block (B).
4. Connect the below wires:
 1. Earthing wire (C)
 2. Neutral wire (D)
 3. AC input wire (E)

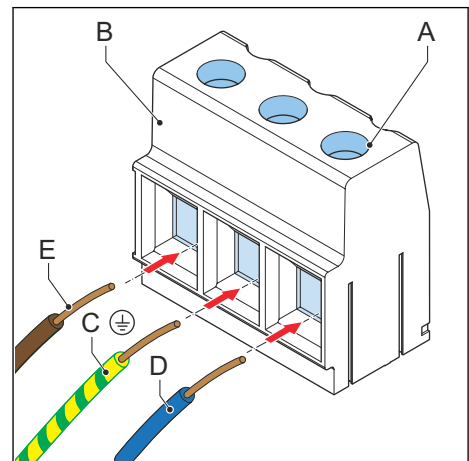

Refer to section 11.11.

5. Tighten the screws (A) to the correct torque. For the specification, refer to section 11.15.



7.3.2 Connect the AC input cable, 3 phase (IEC portfolio)

Preliminary requirements

	<ul style="list-style-type: none"> • Torque screwdriver 		<ul style="list-style-type: none"> • AC input cable (3 phase, TN, TT networks)
---	--	---	---

Procedure

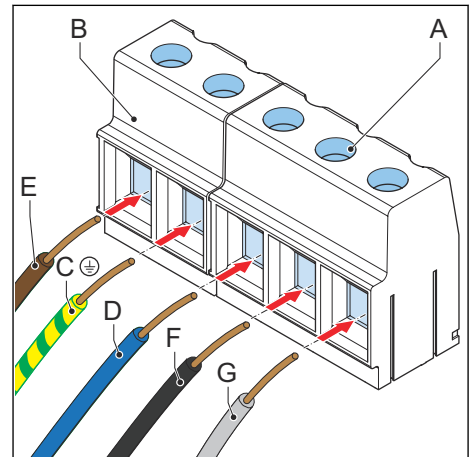

1. Loosen the screws (A).
 2. Insert the cable connector into the terminal block (B).
 3. Connect these wires:
 1. Earthing wire (C)
 2. Neutral wire (D)
 3. L1 (E)
 4. L2 (F)
 5. L3 (G)
- Refer to section 11.11.
4. Tighten the screws (A) to the correct torque. For the specification, refer to section 11.15.



7.3.3

Connect the AC input cable (UL portfolio)

Preliminary requirements

	<ul style="list-style-type: none"> • Torque screwdriver 		<ul style="list-style-type: none"> • AC input cable (1 phase)
--	--	--	--

Procedure

1. Loosen the screws (A).
 2. Strip the wires. For the specification, refer to section 11.13.2.
 3. Insert the cable connector into the terminal block (B).
 4. Connect the below wires:
 1. Earthing (grounding) wire (C)
 2. Neutral wire (D)
 3. L2 AC input wire (F)
 4. L1 AC input wire (E)
- Refer to section 11.11.
5. Tighten the screws (A) to the correct torque. For the specification, refer to section 11.15.

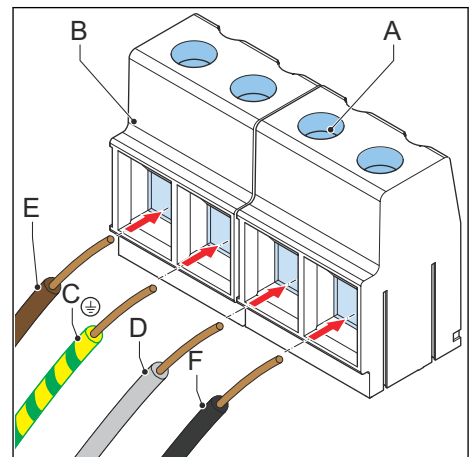

7.3.4

Secure the cables

Preliminary requirements

	<ul style="list-style-type: none"> • Torque screwdriver 		<ul style="list-style-type: none"> • Strain relief for the cable
---	--	---	---

Procedure

1. Secure the cables (A) with the strain relief (B).
2. Install the two screws (C) of the strain relief.

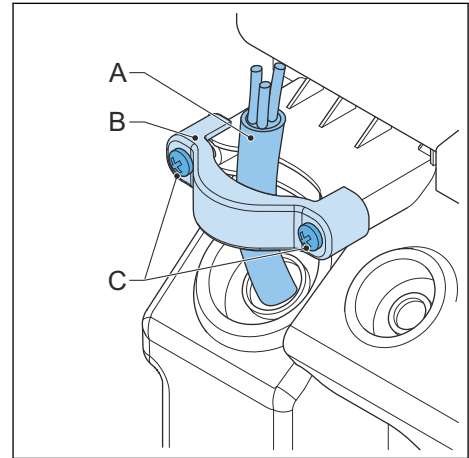

7.4 Communication connections

7.4.1 Insert the Ethernet cable

Preliminary requirements

<input checked="" type="checkbox"/> <input type="checkbox"/>	<ol style="list-style-type: none"> 1. The cabinet cover is removed. Refer to section 9.1. 2. The maintenance cover is removed. Refer to section 9.3.
---	--

Procedure

1. Remove the grommet (A) from the EVSE.
2. Make a hole in the center of the grommet.
3. Install the grommet.
4. Put the Ethernet cable (B) through the cable inlet hole.

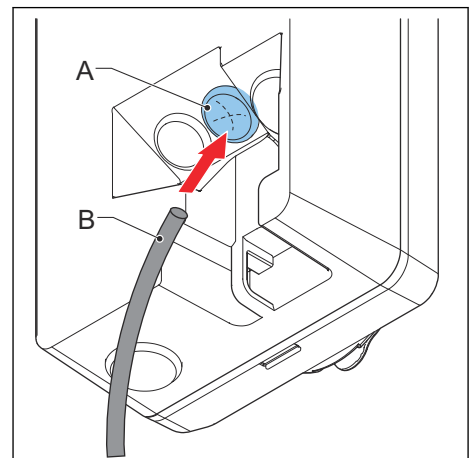

7.4.2 Connect the Ethernet cable

Preliminary requirements

<input checked="" type="checkbox"/> <input checked="" type="checkbox"/>	<ol style="list-style-type: none"> 1. The Ethernet cable is inserted. Refer to section 7.4.1.
--	--

If your EVSE has two Ethernet connections, it is possible to connect multiple EVSEs in a chain. Only the first EVSE is connected to the PC, router or gateway. Only the Ethernet connection is shared, there is no communication between the EVSEs.

Procedure

1. Put the RJ45 plug (A) of the Ethernet cable in the primary Ethernet RJ45 socket (B).
2. Connect the Ethernet cable either to a PC, router, or gateway or to the previous EVSE in a chain (C).
3. If you connect EVSEs in a chain, put the RJ45 plug of Ethernet cable to the next EVSE (D) in the secondary Ethernet RJ45 socket (E).

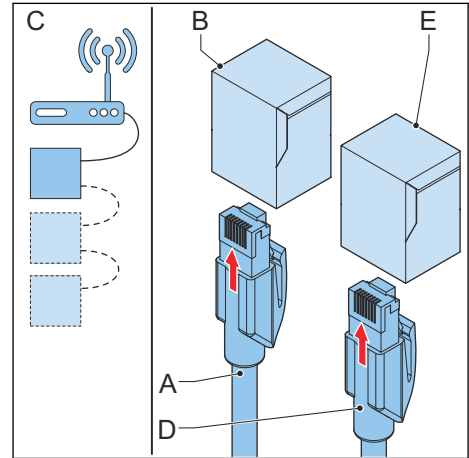

7.4.3

Insert the wires for the smart meter communication

1. Remove the grommet (A) from the EVSE.
2. Make a hole in the center of the grommet.
3. Install the grommet.
4. If necessary, strip the cable to the correct length. Refer to section 11.13.4.
5. Push the wires through the grommet.
6. Put the cable (B) through the inlet hole.

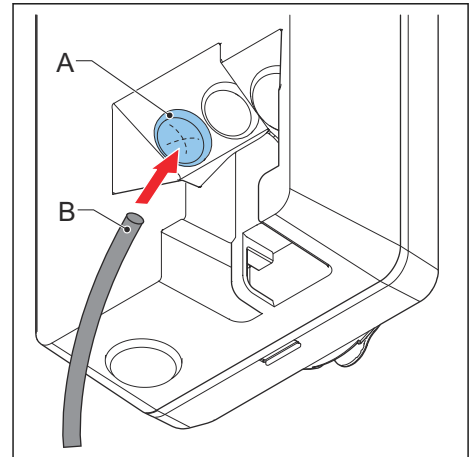

7.4.4

Connect the wires for the smart meter communication

Connect the smart meter with ModBus RTU (RS485) to the EVSE.

Preliminary requirements

	<ul style="list-style-type: none"> • Slotted screwdriver 		<ul style="list-style-type: none"> • Smart meter with ModBus RTU interface • Wire for RS485. Refer to section 11.13.4. Obey the local rules for the correct wire insulation rating.
--	---	--	---

Procedure

1. Remove the plug (A) of the terminal block (B) from the terminal block (B) of the smart meter connection.
2. Connect the wires:
 - a. Connect the positive wire (C).
 - b. Connect the negative wire (D).
 - c. If the smart meter has a common isolated ground for shielded wire, connect the wire (E).
3. Tighten the screws to the correct torque. For the specification, refer to section 11.15.
4. Install the plug on the terminal block.

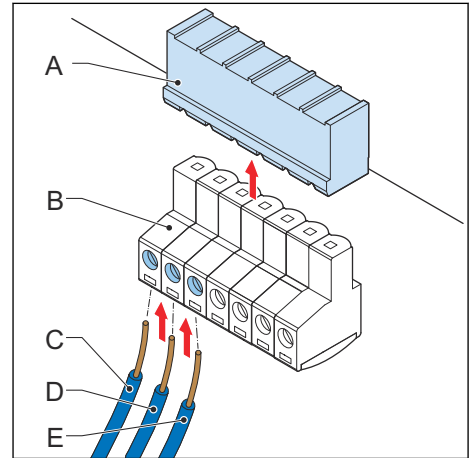

7.4.5 Insert the Nano-M2M SIM card

Preliminary requirements

	<ul style="list-style-type: none"> • A Nano-M2M SIM card from the provider of the mobile network. Refer to section 11.12.
---	--

Procedure



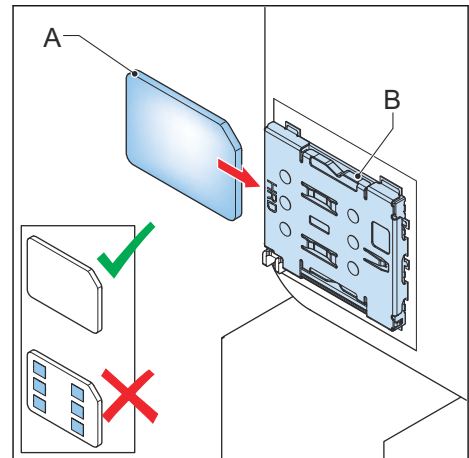

1. Insert the Nano-M2M SIM card (A) into the socket (B). Make sure that the position of the connection points is correct.



7.5 Replace the EV charge cable

7.5.1 Replace the EV charge cable, 1 phase (IEC portfolio)

Preliminary requirements

	<ol style="list-style-type: none"> 1. The EV charge cable is defective. 		<ul style="list-style-type: none"> • Torque screwdriver
	<ol style="list-style-type: none"> 1.  		<ul style="list-style-type: none"> • EV charge cable within the specifications. Refer to section 11.13.7.

Procedure

1. Get access to the EV charge cable connection:
 - a. Remove the cabinet cover. Refer to section 9.1.
 - b. Remove the inner cover. Refer to section 9.5.
2. Disconnect the EV charger 2-pin connector (A) that is receptacle to the CP/PP connector.
3. Loosen the screws (B) on the terminal block output connector (C).
4. Disconnect the wires:
 - L1 wire (D)
 - Earthing wire (E)
 - Neutral wire (F)
5. Remove the EV charge cable.
6. Connect the new EV charge cable:
 - a. Connect the wires.
 - b. Tighten the screws (B) to the correct torque. For the specification, refer to section 11.15.
 - c. Connect the EV charger 2-pin connector that is receptacle to the CP/PP connector.
7. Prepare for operation:
 - a. Install the inner cover. Refer to section 9.6.
 - b. Install the cabinet cover. Refer to section 9.2.

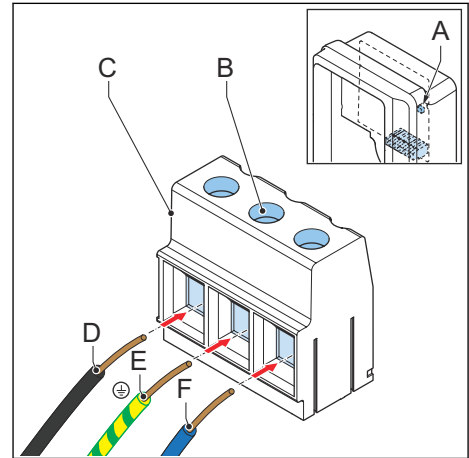

7.5.2

Replace the EV charge cable, 3 phase (IEC portfolio)

Preliminary requirements

	<p>1. The EV charge cable is defective.</p>		<ul style="list-style-type: none"> • Torque screwdriver
	<p>1. </p>		<ul style="list-style-type: none"> • EV charge cable within the specifications. Refer to section 11.13.

Procedure

1. Get access to the EV charge cable connection:
 - a. Remove the cabinet cover. Refer to section 9.1.
 - b. Remove the inner cover. Refer to section 9.5.
2. Disconnect the EV charger 2-pin connector (A) that is receptacle to the CP/PP connector.
3. Loosen the screws (B) on the terminal block output connector (C).
4. Disconnect the wires:
 - Neutral wire (D)
 - L2 (E)
 - Earthing wire (F)
 - L3 (G)
 - L1 (H)
5. Remove the EV charge cable.
6. Connect the new EV charge cable:
 - a. Connect the wires.
 - b. Tighten the screws (B) to the correct torque. For the specification, refer to section 11.15.
 - c. Connect the EV charger 2-pin connector that is receptacle to the CP/PP connector.
7. Prepare for operation:
 - a. Install the inner cover. Refer to section 9.6.
 - b. Install the cabinet cover. Refer to section 9.2.

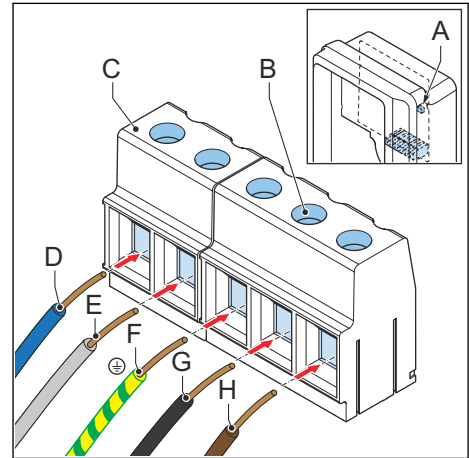

7.5.3 Replace the EV charge cable (UL portfolio)

Preliminary requirements

	<p>1. The EV charge cable is defective.</p>		<ul style="list-style-type: none"> • Torque screwdriver
	<p>1. </p>		<ul style="list-style-type: none"> • EV charge cable within the specifications. Refer to section 11.13.8.

Procedure

1. Get access to the EV charge cable connection:
 - a. Remove the cabinet cover. Refer to section 9.1.
 - b. Remove the inner cover. Refer to section 9.5.
2. Disconnect the EV charger 2-pin connector (A) that is receptacle to the CP/PP connector.
3. Loosen the screws (B) on the terminal block output connector (C).
4. Disconnect the wires:
 - L2 (D)
 - Earthing (grounding) wire (E)
 - L1 (F)
5. Remove the EV charge cable.
6. Connect the new EV charge cable:
 - a. Connect the wires.
 - b. Tighten the screws (B) to the correct torque. For the specification, refer to section 11.15.
 - c. Connect the EV charger 2-pin connector that is receptacle to the CP/PP connector.
7. Prepare for operation:
 - a. Install the inner cover. Refer to section 9.6.
 - b. Install the cabinet cover. Refer to section 9.2.

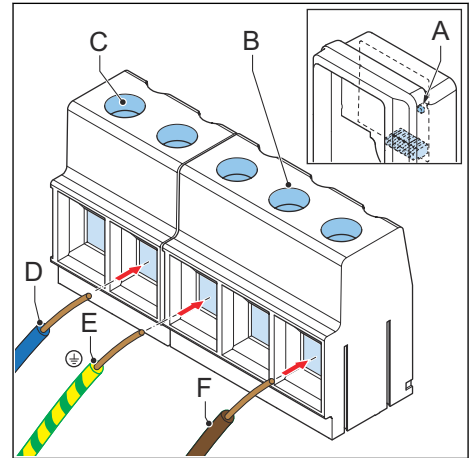

8 Commissioning

8.1 General commissioning procedure

Preliminary requirements

	<ul style="list-style-type: none"> • Mobile device
---	---



Warning: Only use this commissioning procedure for domestic use of the EVSE and commissioning with the *TerraConfig* app. For all other methods of commissioning, do not do the commissioning. Contact your local representative of the manufacturer. Refer to section 1.12.

Procedure

1. Download the *TerraConfig* app.
 - For an Android OS mobile device, go to Google Play Store.
 - For an iOS mobile device, go to Apple Store.
2. Energize the EVSE. Refer to section 8.2.
3. Set up the EVSE. Refer to section 8.3.

8.2 Energize the EVSE

1. Close the breaker that supplies the power to the EVSE.



Warning:

Hazardous voltage

- Be careful when you work with electricity.
- The power supply comes on.
- A series of self-checks start, to make sure that the EVSE works correctly and safely.
- If the EVSE detects a problem, the error LED comes on.

8.3 Set up the EVSE

Preliminary requirements

	<ul style="list-style-type: none"> • Mobile device with the <i>TerraConfig</i> app 		<ul style="list-style-type: none"> • Label with PIN. Refer to section 11.6.
---	---	---	--

Procedure

1. Open the *TerraConfig* app.
2. Enter the PIN.
3. Do these steps, on the *TerraConfig* app:
 - a. Update the product firmware. Do this step again until the *TerraConfig* app does not detect newer firmware.
 - b. Adjust the parameter settings for your EVSE configuration.

9 Access to parts

9.1 Remove the cabinet cover

1. Remove these parts:
 - Screws (A)
 - Cabinet cover (B)

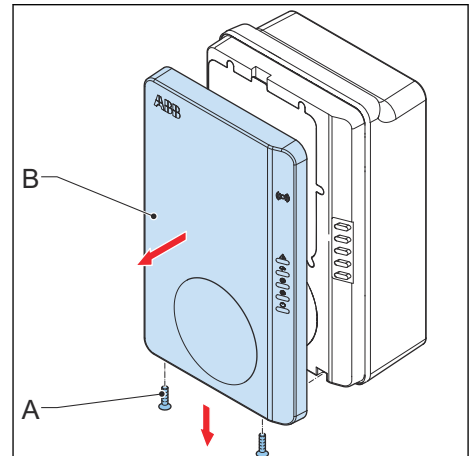

9.2 Install the cabinet cover

Preliminary requirements

	<ol style="list-style-type: none"> 1. The maintenance cover is installed. 		<ul style="list-style-type: none"> • Anti-tamper label
--	--	--	---

Procedure

1. Install these parts:
 - Cabinet cover (A)
 - Screws (B)
2. Seal the cabinet cover to the cabinet. Use the anti-tamper label (C).¹

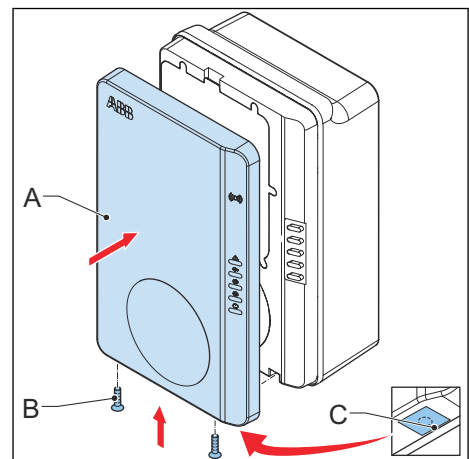



¹ This step is only necessary for an MID certified EVSE.

9.3 Remove the maintenance cover

9.3.1 Remove the maintenance cover (EVSE without display)

Preliminary requirements

<input checked="" type="checkbox"/>  <input checked="" type="checkbox"/>  <input type="checkbox"/> 	1. The cabinet cover is removed.
--	----------------------------------

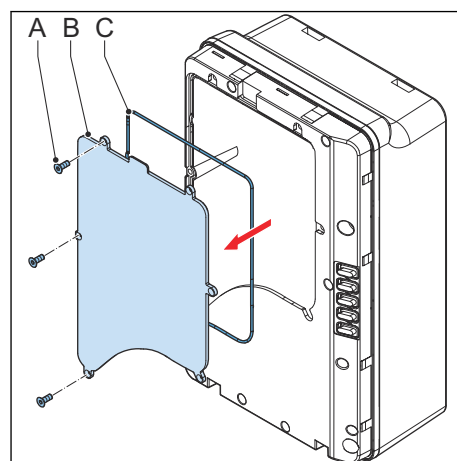

Procedure

1. Remove these parts:
 - Screws (A)
 - Maintenance cover (B)
 - Rubber seal (C)
2. Clean the rubber seal.
3. If you see damage to the rubber seal, to these steps:
 - a. Discard the rubber seal. Refer to section 3.8.
 - b. Order a new rubber seal at your local representative of the manufacturer.



9.3.2 Remove the maintenance cover (EVSE with display)

Preliminary requirements

<input checked="" type="checkbox"/>  <input checked="" type="checkbox"/>  <input type="checkbox"/> 	1. The cabinet cover is removed.
--	----------------------------------

Procedure

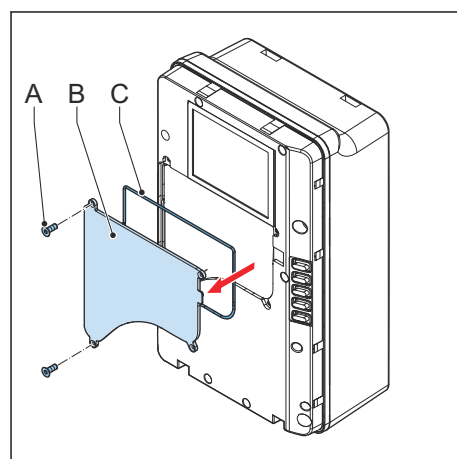

1. Remove these parts:
 - Screws (A)
 - Maintenance cover (B)
 - Rubber seal (C)
2. Clean the rubber seal.
3. If you see damage to the rubber seal, to these steps:
 - a. Discard the rubber seal. Refer to section 3.8.
 - b. Order a new rubber seal at your local representative of the manufacturer.



9.4 Install the maintenance cover

9.4.1 Install the maintenance cover (EVSE without display)

Preliminary requirements

<input checked="" type="checkbox"/>  <input checked="" type="checkbox"/>  <input type="checkbox"/> 	1. The inner cover is installed.
--	----------------------------------



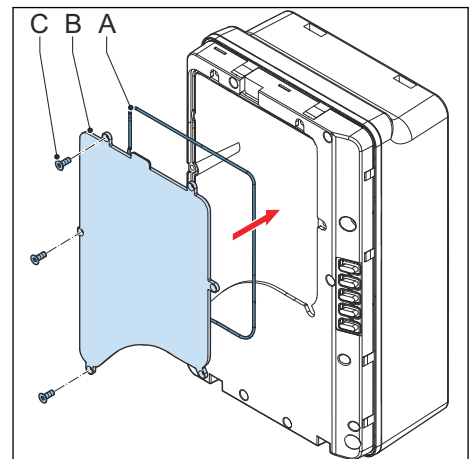

Procedure

1. Install these parts:
 - Rubber seal (A)
 - Maintenance cover (B)
 - Screws (C)



9.4.2 Install the maintenance cover (EVSE with display)

Preliminary requirements

<input checked="" type="checkbox"/>  <input checked="" type="checkbox"/>  <input type="checkbox"/> 	1. The inner cover is installed.		<ul style="list-style-type: none"> • Anti-tamper label
--	----------------------------------	--	---

Procedure

1. Install these parts:
 - Rubber seal (A)
 - Maintenance cover (B)
 - Screws (C)
2. Seal the maintenance cover to the cabinet. Use the anti-tamper label (D).²

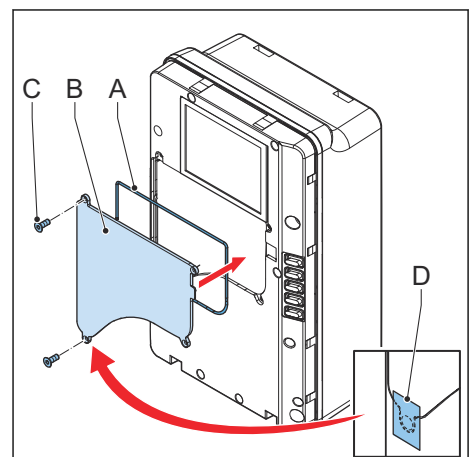





² This step is only necessary for an MID certified EVSE.

9.5 Remove the inner cover

9.5.1 Remove the inner cover (EVSE without display)

Preliminary requirements

<input checked="" type="checkbox"/>  <input checked="" type="checkbox"/>  <input checked="" type="checkbox"/>  <input type="checkbox"/> 	1. The cabinet cover is removed.
---	----------------------------------



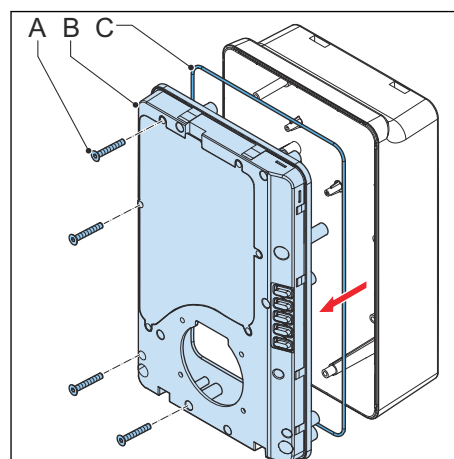

Procedure

1. Remove these parts:
 - Screws (A)
 - Inner cover (B)
 - Rubber seal (C)
2. Clean the rubber seal.
3. If you see damage to the rubber seal, to these steps:
 - a. Discard the rubber seal. Refer to section 3.8.
 - b. Order a new rubber seal at your local representative of the manufacturer.



9.5.2 Remove the inner cover (EVSE with display)

Preliminary requirements

<input checked="" type="checkbox"/>  <input checked="" type="checkbox"/>  <input checked="" type="checkbox"/>  <input type="checkbox"/> 	1. The cabinet cover is removed.
---	----------------------------------

Procedure

1. Remove these parts:
 - Screws (A)
 - Inner cover (B)
 - Rubber seal (C)
2. Clean the rubber seal.
3. If you see damage to the rubber seal, to these steps:
 - a. Discard the rubber seal. Refer to section 3.8.
 - b. Order a new rubber seal at your local representative of the manufacturer.

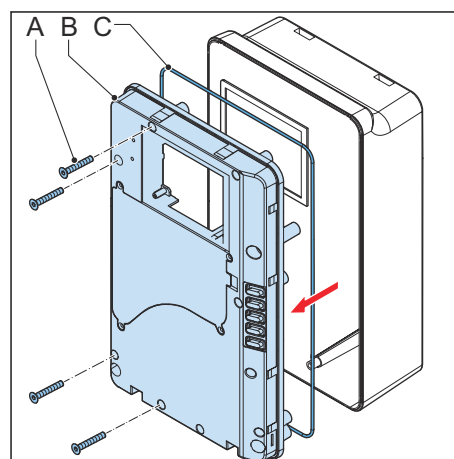

9.6 Install the inner cover

9.6.1 Install the inner cover (EVSE without display)

1. Install these parts:
 - Rubber seal (A)
 - Inner cover (B)
 - Screws (C)

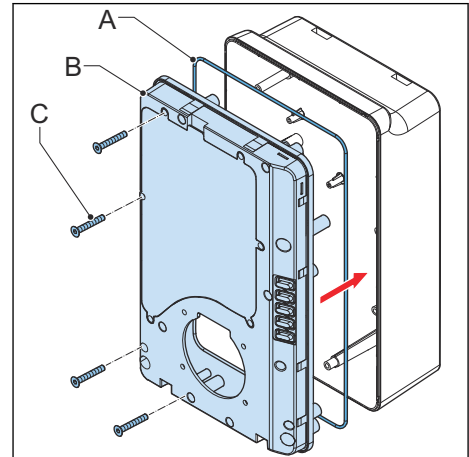

9.6.2 Install the inner cover (EVSE with display)

Preliminary requirements

	<ul style="list-style-type: none">• Anti-tamper label
---	---

Procedure

1. Install these parts:
 - Rubber seal (A)
 - Inner cover (B)
 - Screws (C)
2. Seal the inner cover to the cabinet.
Use the anti-tamper label (D).³

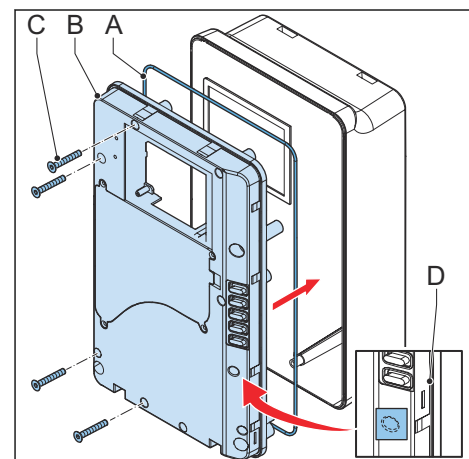

³ This step is only necessary for an MID certified EVSE.

10 Troubleshooting

10.1 Troubleshooting procedure

1. Try to find a solution for the problem with the aid of the information in this document.
2. If you cannot find a solution for the problem, contact your local representative of the manufacturer. Refer to section 1.12.

10.2 Troubleshooting table (IEC portfolio)

Problem (error code)	Possible cause	Possible solution
Residual current detected (0x0002)	There is residual current (30mA AC or 6mA DC) in the charge circuit. Current leaks into the ground.	<ol style="list-style-type: none"> 1. De-energize the EVSE. Refer to section 10.4. 2. Contact your local representative of the manufacturer or a qualified electrical contractor. Refer to section 1.12.
PE missing or swap neutral and phase (0x0004)	The EVSE is not earthed correctly.	<ol style="list-style-type: none"> 1. Do a check of the protective earth line of the connector of the AC input. 2. Install the protective earth conductor.
	The neutral and phase wires are swapped.	<ol style="list-style-type: none"> 1. Examine the electrical connections. 2. Make sure that the connection of the phase and line and neutral wires is correct. 3. If necessary, adjust the electrical connections. Refer to chapter 7.
Over voltage (0x0008)	The maximum voltage on the power input is too high.	Make sure that the voltage from the grid is not more than specified.
Under voltage (0x0010)	The voltage on the power input is not sufficient.	Make sure that the voltage from the grid is not less than specified.
Over current (0x0020)	There is an overload on the EV side.	<ol style="list-style-type: none"> 1. Examine the EV charge cable connection. 2. Connect the EV charge cable correctly.
Severe over current (0x0040)	There is an overload on the EV side.	<ol style="list-style-type: none"> 1. Examine the EV charge cable connection. 2. Connect the EV charge cable correctly.

Problem (error code)	Possible cause	Possible solution
Over temperature (0x0080)	The internal temperature is too high.	<ol style="list-style-type: none"> 1. Do a check of the operation temperature on the product label. If the ambient temperature is too high, the EVSE will decrease the output current automatically. 2. If it is necessary, install the EVSE in an environment with a lower ambient temperature. 3. Make sure that the voltage from the grid is not more than specified. 4. If you can not solve the problem, do not use the EVSE. Contact your local company representative or a qualified electrical contractor. Refer to section 1.12.
Power relay fault (0x0400)	The relay contact is detected in wrong state or has damage.	<ol style="list-style-type: none"> 1. Examine the relay contact. 2. If necessary, adjust the current. 3. If necessary, replace the relay contact.
Internal communication failure (0x0800)	The printed circuit boards of the EVSE fail to communicate with each other.	<ol style="list-style-type: none"> 1. Connect the EVSE to the internet. 2. Do a check of the WiFi signal at the site 3. Do a check of the Nano-SIM card connection and the 4G signal strength at the site.
E-Lock failure (0x1000)	Error to lock / unlock the charge connector.	<ol style="list-style-type: none"> 1. Examine the connection of the EV charge cable. 2. If necessary, connect the EV charge cable.
Missing phase (0x2000)	B and C phase are missing or one of these phases is missing.	<ol style="list-style-type: none"> 1. Examine the electrical connections. 2. Make sure that the connection of the phase and line and neutral wires is correct. 3. If necessary, adjust the electrical connections. Refer to chapter 7.

Problem (error code)	Possible cause	Possible solution
Modbus communication lost (0x4000)	The Modbus communication is lost.	<ol style="list-style-type: none"> 1. Do a check on the connection of the wires and the polarity. 2. Do a check if all addresses are unique. 3. Do a check if the baud rate is the same as the other device or meter. 4. Do a check if the parity value of the other device or meter agrees with the EVSE 'None'. 5. Do a check if the stop bit and data bit are the same on the other device or meter.
The display shows that the EV is not ready for the charge session or the <i>ChargerSync</i> app shows 'waiting for EV'	The EV is unavailable	Wake up the EV. Refer to the user manual.
The EV is not charged	There is a problem with the EVSE	<ol style="list-style-type: none"> 1. Make sure that the power supply to the EVSE is on. 2. Examine the EVSE to find if is working correctly. 3. Examine the <i>ChargerSync</i> app and the charge LED to make sure that the charging session is authorized. 4. Start the charging session.
	The EV charge cable is defective.	<ol style="list-style-type: none"> 1. Examine the EV charge cable. 2. If the standard supplied EV charge cable is defective, replace the EV charge cable. Refer to section 7.5.
The EV connection or authorization process fails	The EV charge cable is defective.	<ol style="list-style-type: none"> 1. Examine the EV charge cable. 2. If the standard supplied EV charge cable is defective, replace the EV charge cable. Refer to section 7.5.

Problem (error code)	Possible cause	Possible solution
	The EV charge cable is not connected correctly.	<ol style="list-style-type: none"> 1. Examine the connection of the EV charge cable. 2. If necessary, connect the EV charge cable.
	There is a problem with the <i>ChargerSync</i> app or the RFID card.	<ol style="list-style-type: none"> 1. Make sure that the user has registered in the <i>ChargerSync</i> app. 2. Make sure that you use a RFID card that the manufacturer provided. 3. Make sure that the RFID card is added on the <i>ChargerSync</i> app. 4. Start the <i>ChargerSync</i> app. 5. Start the authorization process.

10.3 Troubleshooting table (UL portfolio)

Problem (error code)	Possible cause	Possible solution
Residual current detected (0x0002)	There is residual current (20mA AC) in the charge circuit. Current leaks into the ground.	<ol style="list-style-type: none"> 1. De-energize the EVSE. Refer to section 10.4. 2. Contact your local representative of the manufacturer or a qualified electrical contractor. Refer to section 1.12.
PE missing or swap neutral and phase (0x0004)	The EVSE is not earthed correctly.	<ol style="list-style-type: none"> 1. Do a check of the protective earth line of the connector of the AC input. 2. Install the protective earth conductor.
	The neutral and phase wires are swapped.	<ol style="list-style-type: none"> 1. Examine the electrical connections. 2. Make sure that the connection of the phase and line and neutral wires is correct. 3. If necessary, adjust the electrical connections. Refer to chapter 7.
Over voltage (0x0008)	The maximum voltage on the power input is too high.	Make sure that the voltage from the grid is not more than specified.
Under voltage (0x0010)	The voltage on the power input is not sufficient.	Make sure that the voltage from the grid is not less than specified.

Problem (error code)	Possible cause	Possible solution
Over current (0x0020)	There is an overload on the EV side.	<ol style="list-style-type: none"> 1. Examine the EV charge cable connection. 2. Connect the EV charge cable correctly.
Severe over current (0x0040)	There is an overload on the EV side.	<ol style="list-style-type: none"> 1. Examine the EV charge cable connection. 2. Connect the EV charge cable correctly.
Over temperature (0x0080)	The internal temperature is too high.	<ol style="list-style-type: none"> 1. Do a check of the operation temperature on the product label. If the ambient temperature is too high, the EVSE will decrease the output current automatically. 2. If it is necessary, install the EVSE in an environment with a lower ambient temperature. 3. Make sure that the voltage from the grid is not more than specified. 4. If you can not solve the problem, do not use the EVSE. Contact your local company representative or a qualified electrical contractor. Refer to section 1.12.
Power relay fault (0x0400)	The relay contact is detected in wrong state or has damage.	<ol style="list-style-type: none"> 1. Examine the relay contact. 2. If necessary, adjust the current. 3. If necessary, replace the relay contact.
Internal communication failure (0x0800)	The printed circuit boards of the EVSE fail to communicate with each other.	<ol style="list-style-type: none"> 1. Connect the EVSE to the internet. 2. Do a check of the WiFi signal at the site 3. Do a check of the Nano-SIM card connection and the 4G signal strength at the site.
E-Lock failure (0x1000)	Error to lock / unlock the charge connector.	<ol style="list-style-type: none"> 1. Examine the connection of the EV charge cable. 2. If necessary, connect the EV charge cable.

Problem (error code)	Possible cause	Possible solution
Missing phase (0x2000)	B and C phase are missing or one of these phases is missing.	<ol style="list-style-type: none"> 1. Examine the electrical connections. 2. Make sure that the connection of the phase and line and neutral wires is correct. 3. If necessary, adjust the electrical connections. Refer to chapter 7.
Modbus communication lost (0x4000)	The Modbus communication is lost.	<ol style="list-style-type: none"> 1. Do a check on the connection of the wires and the polarity. 2. Do a check if all addresses are unique. 3. Do a check if the baud rate is the same as the other device or meter. 4. Do a check if the parity value of the other device or meter agrees with the EVSE 'None'. 5. Do a check if the stop bit and data bit are the same on the other device or meter.
The display shows that the EV is not ready for the charge session or the <i>ChargerSync</i> app shows 'waiting for EV'	The EV is unavailable	Wake up the EV. Refer to the user manual.
The EV is not charged	There is a problem with the EVSE	<ol style="list-style-type: none"> 1. Make sure that the power supply to the EVSE is on. 2. Examine the EVSE to find if it is working correctly. 3. Examine the <i>ChargerSync</i> app and the charge LED to make sure that the charging session is authorized. 4. Start the charging session.
	The EV charge cable is defective.	<ol style="list-style-type: none"> 1. Examine the EV charge cable. 2. If the standard supplied EV charge cable is defective, replace the EV charge cable. Refer to section 7.5.
The EV connection or authorization process fails	The EV charge cable is defective.	<ol style="list-style-type: none"> 1. Examine the EV charge cable. 2. If the standard supplied EV charge cable is defective, replace the EV charge cable. Refer to section 7.5.

Problem (error code)	Possible cause	Possible solution
	The EV charge cable is not connected correctly.	<ol style="list-style-type: none"> 1. Examine the connection of the EV charge cable. 2. If necessary, connect the EV charge cable.
	There is a problem with the <i>ChargerSync</i> app or the RFID card.	<ol style="list-style-type: none"> 1. Make sure that the user has registered in the <i>ChargerSync</i> app. 2. Make sure that you use a RFID card that the manufacturer provided. 3. Make sure that the RFID card is added on the <i>ChargerSync</i> app. 4. Start the <i>ChargerSync</i> app. 5. Start the authorization process.

10.4

De-energize the EVSE

1. Open the breaker that supplies the power to the EVSE.
2. Wait for minimum 1 minute.

11 Technical data

11.1 EVSE Type

The EVSE type is a code.
The code has 10 parts: A1 - A10.

Code part	Description	Value	Meaning of the value
A1	Brand name	Terra AC	-
A2	Type	W	Wallbox
		C	Column
A3	Power output	4	3.7 kW
		7	7.4 kW
		9	9 kW
		11	11 kW
		19	19 kW
		22	22 kW
A4	Cable type or socket	P	Type 1 cable
		G	Type 2 cable
		T	Type 2 socket
		S	Type 2 socket with shutter
A5	Cable length	-	No cable
		5	5 m
		8	8 m
A6	Authorization	R	RFID enabled
		-	No RFID
A7	Display	D	Yes
		-	No
A8	Metering	M	Certified for MID (only with display)
		-	Not certified for MID
A9	SIM slot	C	Yes
		-	No
A10	Ethernet	-	Single
		D	Daisy-chain

Example

Terra AC W7-P8-RD-MCD-0

- A1 = Brand name = Terra AC
- A2 = Type = wallbox
- A3 = 7, Power output = 7.4 kW

- A4 = Cable type, cable = Type 1
- A5 = 8 m
- A6 = authorization = RFID enabled
- A7 = Display = yes
- A8 = metering = certified for MID
- A9 = SIM slot = applicable
- A10 = ethernet = daisy-chain
- The '0' is an empty field.

11.2 General specifications

Parameter	Specification
Safety standards	<ul style="list-style-type: none"> • IEC/EN 61851-1, IEC/EN 62311, IEC/EN 62479, IEC/EN 62955 • UL 2594, UL 2231-1, UL 2231-2, UL 1998 • NMX-J-667-ANCE • CSA C22.2. NO.280
Certification	<p>IEC portfolio:</p> <ul style="list-style-type: none"> • Single phase • Single phase with display and MID certificate • Three phase • Three phase with display and MID certificate <hr/> <p>UL portfolio:</p> <ul style="list-style-type: none"> • Single phase • Single phase with display
IP or NEMA rating	The product label shows the specification. Refer to section 2.3.
IK rating according to IEC 62262 (enclosure and display)	IK10 IK8+ for an operation temperature between -35 and -30 °C
Codes and standards	IEC 61851-21-2, EN 61000-6-1, EN 61000-6-2, EN 61000-6-3, EN 61000-6-4, EN 61000-3-2, EN 61000-3-3, EN 61000-3-11, EN 61000-3-12 CE RED- WLAN / RFID / E-UTRA: EN 300 328 V2.1.1, EN 300 330 V2.1.1, EN 301 908-1 V11.1.2, EN 301 908-13 EN 50470-1, EN 50470-3 FCC Part 15 Class B

Parameter	Specification
	FCC Part 15 Class B ENERGY STAR
Power consumption	In stand-by mode:
<ul style="list-style-type: none"> • CE model • MID model • UL model • UL model with display 	<ul style="list-style-type: none"> • 4 W • 4.6 W • 3.6 W (ENERGY STAR compliant) • 4.6 W

11.3 Ambient conditions

Parameter	Specification
Operation temperature	-35°C ⁴ to +50°C
Operation temperature for MID certified models	-30°C to +55°C
Storage temperature	-40°C to +80°C
Storage conditions	Indoor, dry
Relative humidity	<95%, non-condensing



11.4 Mass

EVSE type	Mass [kg]
Terra AC wallbox, Type 2 with socket (IEC portfolio)	3.0
Terra AC wallbox, Type 2 with an EV charge cable (IEC portfolio)	7.0
Terra AC wallbox, Type 1 (UL portfolio)	7.0

⁴ Based on manufacturer test results

11.5 Protective device compliance

11.5.1 Protective device compliance (IEC portfolio)

Requirements	Specifications
Dedicated upstream protection device(s)	Options: <ul style="list-style-type: none"> • RCD (Type A minimum) + MCB • RCBO (Type A minimum), (for example: ABB model PN: DS201 C40 A30)
Upstream overcurrent protection breaker (for example: RCBO or MCB).  Note: The breaker value depends on the diameter and the length of the cable, the EVSE rating, and the environmental parameters (for the electrician to decide).	Breaker rating: <ul style="list-style-type: none"> • 40 A for a 32 A rated EVSE • 20 A for a 16 A rated EVSE Tripping characteristics: type C
The breaker serves as the main disconnect switch to the EVSE.	
Upstream residual-current device (RCD)	Minimum Type A, with a rated residual operation current of maximum 30 mA  Note: Internal to EVSE is DC fault current monitoring > 6 mA

11.5.2 Protective device compliance (UL portfolio)

Requirements	Specifications
Dedicated upstream protection device(s)	Breaker
EVSE internal Ground Fault Protection	20 mA AC
Upstream overcurrent protection breaker  Note: The breaker value depends on the diameter and the length of the cable, the EVSE rating, and the environmental parameters (for the electrician to decide).	Breaker rating: <ul style="list-style-type: none"> • 40 A for a 32 A rated EVSE • 20 A for a 16 A rated EVSE Tripping characteristics: type C
The breaker serves as the main disconnect switch to the EVSE.	

11.5.3 Protective device compliance (Singapore)

Requirements	Specifications
Dedicated upstream safety device(s)	Emergency stop button
Dedicated upstream protection device(s)	Options: <ul style="list-style-type: none"> • RCD (Type A minimum) + MCB • RCBO (Type A minimum), for example: ABB model PN: DS201 C40 A30
Upstream residual-current device (RCD)	Minimum Type A, with a rated residual operation current of maximum 30 mA
	 Note: Internal to EVSE is DC fault current monitoring > 6 mA

11.6 Parts included in the delivery

Parameter	Specification
EVSE	Refer to the product label. Refer to section 2.3.
Upper mounting screws	M6 x 60
Plugs for the upper mounting screws (servicable for a brick wall)	8 x 60 mm
Lower mounting screws	M6 x 120
Plugs for the lower mounting screws (servicable for a brick wall)	10 x 60 mm
Installation template	-
RFID card	MIFARE
Label with PIN	To log in to the <i>TerraConfig</i> app.

11.7 Required tools for installation

Parameter	Specifications
Hammer	-
Spirit level	-
Drill	-
Torque screwdriver, cross	-
Torque screwdriver, slotted	For terminal blocks and plugs with 5 mm pitch

11.8 Requirements for the wall

Parameter	Specifications
Wall thickness	Minimum 89 mm (3.5 inch)
Wall strength	The wall must be serviceable for the items listed below: <ol style="list-style-type: none"> 1. The weight of the EVSE. Refer to section 11.2. 2. The torque for the lower mounting screws. Refer to section 11.15.
Wall material	The mounting surface must be flat and stable, for example a finished, brick or concrete wall.
Length of the upper screws that stays out of the wall	6 mm (0.24 inch)

11.9 Noise level

Parameter	Specification
Noise level	Less than 35 dB(A)

11.10 Dimensions

11.10.1 AC input with socket, cable Type 2

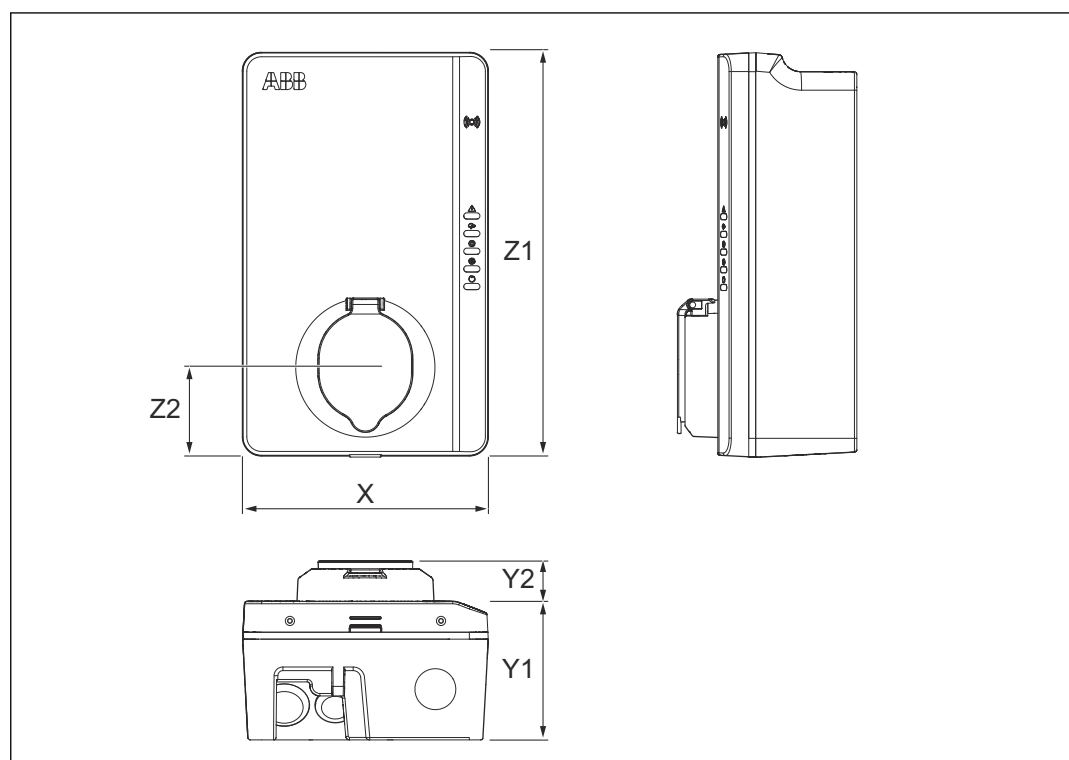

X	Width of the EVSE	Z1	Height of the EVSE
Y1	Depth of the EVSE	Z2	Distance from the bottom of the EVSE to the center of the socket.
Y2	Depth of the socket		

Parameter	Specification [mm]
X	195
Y1	110
Y2	33
Z1	320
Z2	70

11.10.2 AC input with EV charge cable

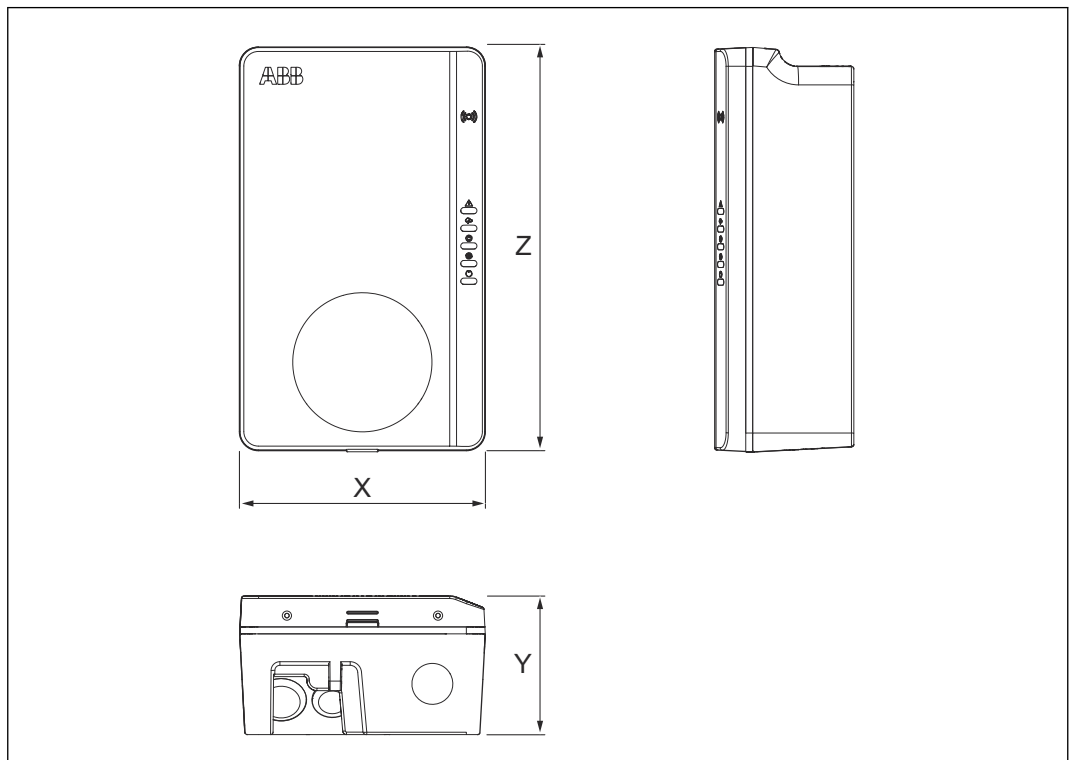

X	Width of the EVSE	Z	Height of the EVSE
Y	Depth of the EVSE		

Parameter	Specification [mm]
X	195
Y	110
Z	320

11.10.3 Space requirements for installation

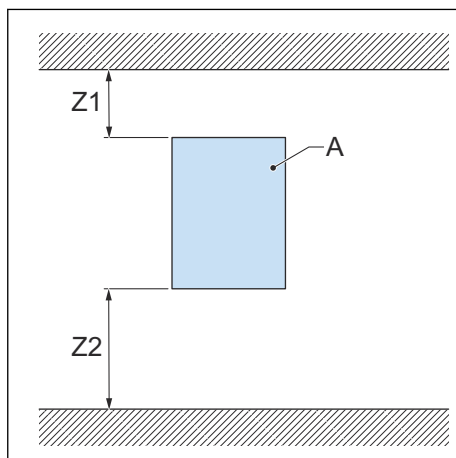

A EVSE

Parameter	Specification	
	[mm]	[in]
Z1	> 200	> 8
Z2 (indoor use)	450 to 1200	18 to 48
Z2 (outdoor use)	600 to 1200	24 to 48

11.11 AC input specifications

11.11.1 General specifications

Parameter	Specification
Earthing systems	IT
	TT
	TN-S
	TN-C-S
Frequency	50 Hz or 60 Hz
Oversvoltage category	Category III
Protection	Overcurrent
	Oversvoltage
	Undersvoltage
	Earth fault, including DC leakage protection ⁵
	Integrated surge protection

⁵ Only for EVSEs in the IEC portfolio

11.11.2 400 VAC 3-phase with neutral (TT, TN) (IEC portfolio)

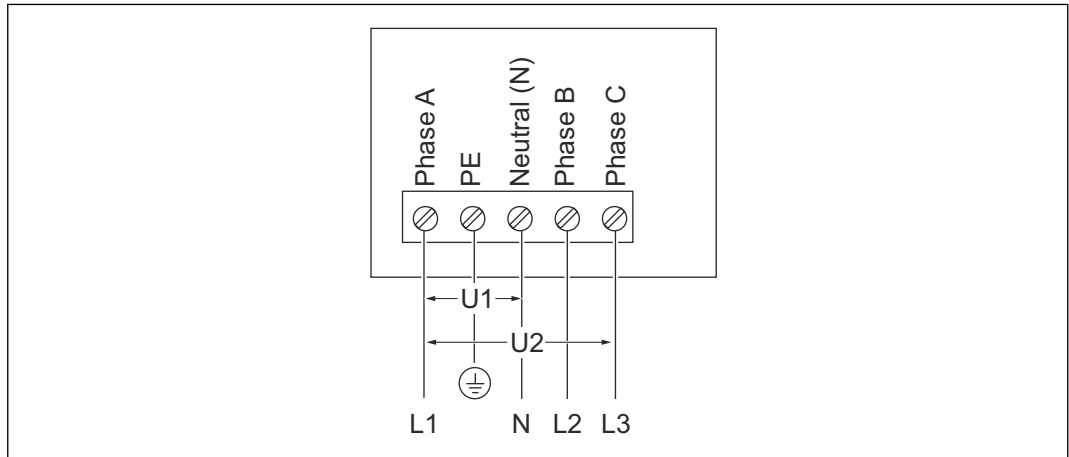

U1 230 VAC, maximum 264 VAC

U2 400 VAC, maximum 460 VAC

11.11.3 230 VAC 1-phase (IEC portfolio)

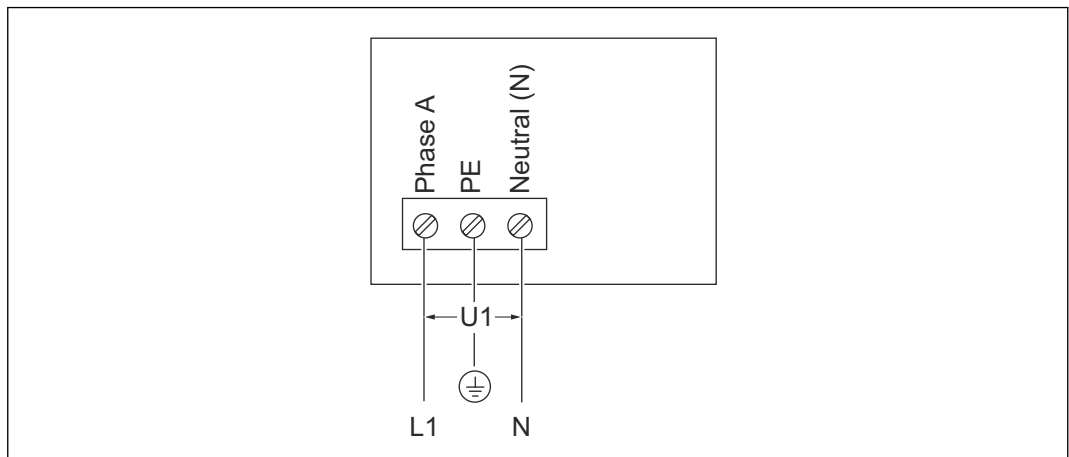

U1 230 VAC, maximum 264 VAC

11.11.4 240 VAC (UL portfolio)

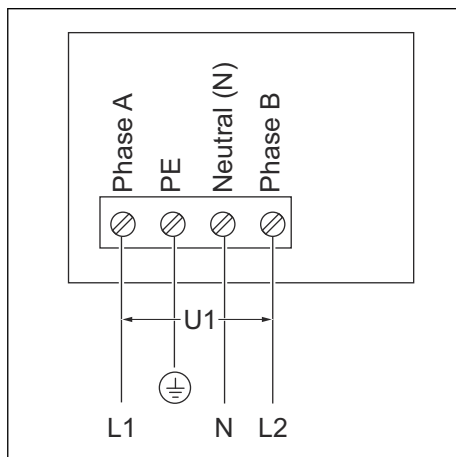

U1 240 VAC, maximum 264 VAC

11.11.5 AC input specifications (IEC portfolio)

Parameter	Specification
Input AC power connection	1 phase or 3 phase
Input voltage (1 phase)	230 V AC
Input voltage (3 phase)	400 V AC
Standby power consumption	4.6 W
Earth (ground) fault protection	30mA AC, 6 mA DC
Maximum input power (1 phase)	3.7 kW (16 A)
	7.4 kW (32 A)
Maximum input power (3 phase)	11 kW (16 A)
	22 kW (32 A)
	0.25-5 (32) A for MID certified models

11.11.6

AC input specifications (UL portfolio)

Parameter	Specification
Input AC power connection	240 V AC
Standby power consumption	3.6 W
Earth (ground) fault protection	internal 20 mA AC CCID

11.12

General logic interface specifications

Parameter	Specification
Connectivity	Mobile communication with Nano-SIM socket type M2M (Machine To Machine): 4G (LTE)
Smart meter communication	Modbus RTU (RS485)
Local controller communication	Modbus TCP/IP (secondary)
Ethernet	1x 10/100 BaseT, RJ45 Socket
Extra ethernet (daisy chain)	1x 10/100 BaseT, RJ45 Socket
WiFi (WAN)	IEEE 802.11 b/g/n, 2.4 GHz
Bluetooth	BLE 5.0
RFID	ISO/IEC 14443A, MIFARE™ Classic, 1K memory
Compatible mobile device operating systems	<ul style="list-style-type: none"> Android 4.4 or higher iOS8 or higher

11.13

Cable specifications

11.13.1

AC input cable (IEC portfolio)

Parameter	Specification
EV charger station connection type	Terminal block and screw
Wire size for the terminal block (allowed)	Cross section: 10 to 2.5 mm ²

Parameter	Specification
Wire size for the terminal block (recommended for 32A EV Charger stations)	Minimum cross-section 6 mm ²
Wire size for the terminal block (recommended for 16A EV Charger stations)	Minimum cross-section 2.5 mm ²
Strip length	10 mm
Cable shielding (optional)	The local rules require shielded cables. The cable shielding must be connected to the PE rail at the two ends of the cable.
Diameter of the phase conductors	Refer to the local rules.
Diameter of the PE conductor	The same as the diameter of the phase conductors

- Consult your local electrical codes for the correct wire size, based on the environment, the conductor type and the rating of the EVSE.
- The wire cross-sectional area is based on the copper wire type.

11.13.2 AC input cable (UL portfolio)

Parameter	Specification
EV charger station connection type	Terminal block and screws
Wire size for the terminal block (allowed)	6 to 12 AWG
Wire size for the terminal block (recommended for 32A EV Charger stations)	Minimum 8 AWG
Wire size for the terminal block (recommended for 16A EV Charger stations)	Minimum 12 AWG
Strip length	10 mm
Cable shielding (optional)	The local rules require shielded cables. The cable shielding must be connected to the PE rail at the two ends of the cable.
Diameter of the phase conductors	Refer to the local rules.
Diameter of the PE conductor	The same as the diameter of the phase conductors

- Consult your local electrical codes for the correct wire size, based on the environment, the conductor type and the rating of the EVSE.
- The wire AWG is based on the copper wire type.

11.13.3 Ethernet cable specifications

Parameter	Specification
EVSE connector type	RJ45 Modular jack
Cable type	Category 5 (Cat 5)

11.13.4 RS485 cable specifications

The RS485 cable specifications apply to smart meter ModBus RTU communication.

Parameter	Specification
Connector type for the EV charging station	Terminal block plug and screws
Conductor type	Twisted pair, shielded cable (recommended)
Conductor size for the terminal block plug (allowed)	IEC portfolio: cross-sectional area: 2.5 mm ² to 0.5 mm ² UL portfolio: 12 AWG to 30 AWG
Conductor size for the terminal block plug (recommended)	Minimum 24 AWG (0.5 mm ²)
Strip length	5 mm
Terminal connections	485A: RS485 Positive/A/D0 485B: RS485 Negative/B/D1 Common isolated ground for shielded cable
ModBus RTU baud rate	9600 bps standard, with <i>TerraConfig</i> app configurable to 4800, 9600, 19200, 38400, 57600 and 115200 bps
ModBus RTU bus primary/secondary	EVSE is Modulus primary/secondary configurable via <i>TerraConfig</i> app
	<ul style="list-style-type: none"> Consult your local electrical codes and the wiring requirements of your smart meter device for the correct wire size. The wire AWG and cross-sectional area are based on the copper wire type.

11.13.5

Dry contacts input

The dry contacts input is the single contact provided by the user.

Parameter	Specifications
EVSE connector type	Terminal block plug and screws
Wire size for the terminal block plug (allowed maximum)	<ul style="list-style-type: none"> 2.5 to 0.5 mm² (IEC portfolio) 12 to 30 AWG (UL portfolio)
Wire size for the terminal block plug (recommended)	24 AWG (0.5 mm ²) minimum
Required torque	0.5 Nm
Strip length	5 mm
Terminal connections	<ul style="list-style-type: none"> PE/Shield: Contact input terminal 1 or 2 Configuration input: Contact input terminal 2 or 1

Wire AWG and cross section: based on a copper wire type

11.13.6

Dry contacts output

The dry contacts input is the single contact in the EVSE.

Parameter	Specifications
EVSE connector type	Terminal block plug and screws
Wire size for the terminal block plug (allowed maximum)	<ul style="list-style-type: none"> 2.5 to 0.5 mm² (IEC portfolio) 12 to 30 AWG (UL portfolio)
Wire size for the terminal block plug (recommended)	20 AWG (0.75 mm ²) minimum
Required torque	0.5 Nm
Strip length	5 mm
Terminal connections	<ul style="list-style-type: none"> Configuration output dry contact 1: Contact output terminal 1 Configuration output dry contact 2: Contact output terminal 2
Contact rated load	125 VAC/30VDC at 3A

The wire AWG and cross section are based on a copper wire type.

11.13.7 EV charge cable specifications (IEC portfolio)

Parameter	Specification [m]
Length	5

11.13.8 EV charge cable specifications (UL portfolio)

Parameter	Specification	
	[m]	[ft]
Length	7.6	25

11.14 AC output specifications

11.14.1 AC output specifications (IEC portfolio)

Parameter	Specification
AC output voltage range (1 phase)	230 V AC
AC output voltage range (3 phase)	400 V AC
Connection standard	<ul style="list-style-type: none"> Type 2 cable Type 2 socket Type 2 socket with shutter <p>According to IEC 62196-1, IEC 62196-2</p>
Current for MID certified models	0.25-5(32) A

11.14.2 AC output specifications (UL portfolio)

Parameter	Specification
AC output voltage range	240 V AC (1 phase)
Connection standard	Type 1 cable according to SAE J1772

11.15 Torque specifications

Parameter	Specification	
	[Nm]	[lb-in]
Terminal block for the AC input	1.2	10.6
Terminal block for the communication wires and the smart meter connections	0.5	4.43
Terminal block for the EV charge cable	1.2	10.6
Lower mounting screws	4.4	38.9

